

NOTES:

- 1. PILOT HOLE DIAMETER TO BE HELD TO: $\varnothing 6.50 \pm 0.076$ mm
- 2. APPROXIMATE TOOL WEIGHT: 1.031 LBS
- 3. CUTTER BLADE SHOWN FOR REFERENCE ONLY, TOOL DESIGNED TO WORK WITH CB25-~~X~~.XXM BLADES.

| REVISIONS | | | | |
|-----------|------|-------------|-------|----------|
| ZONE | REV. | DESCRIPTION | DATE | APPROVED |
| | A | RELEASED | 11/19 | M.Hoyt |

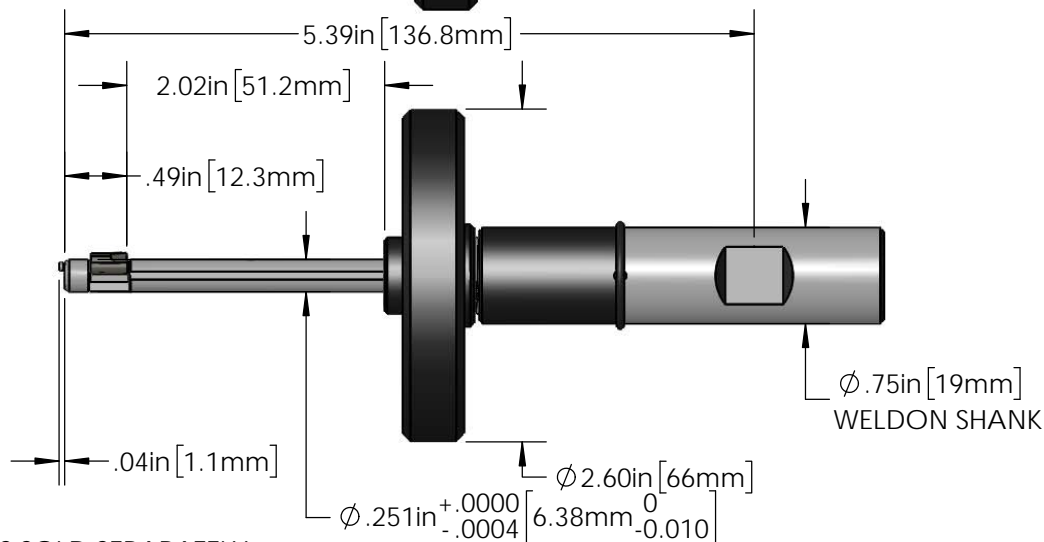
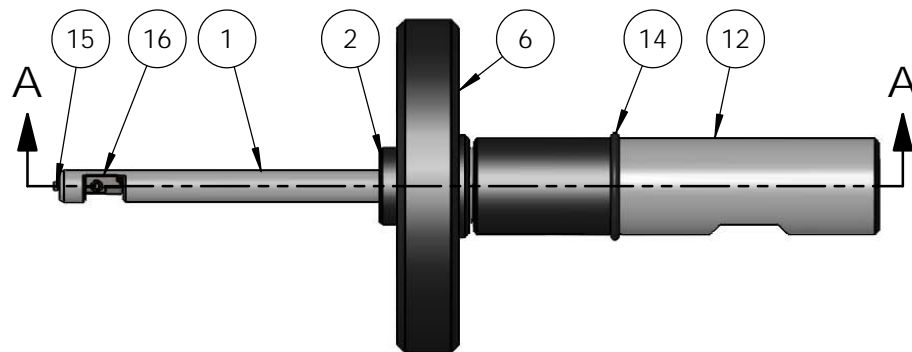
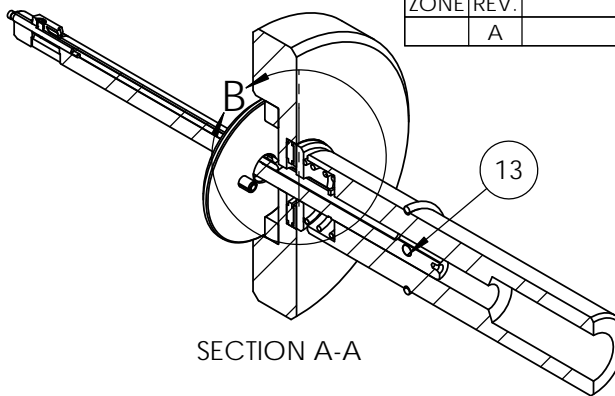
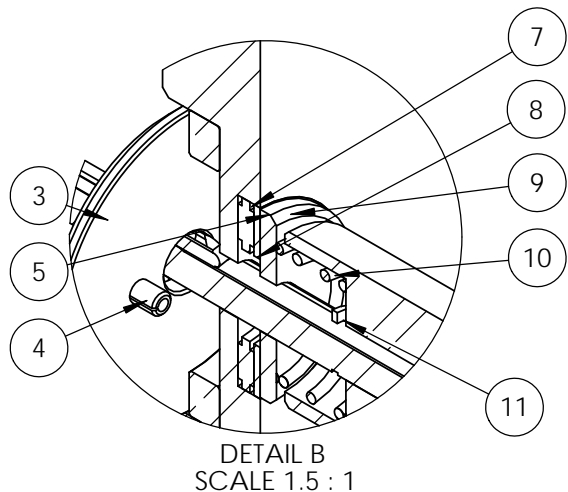

| ITEM NO. | PART NUMBER | DESCRIPTION | OPEN /QTY. | Spare Qty |
|----------|-----------------|-------------------------------------|------------|-----------|
| 1 | 39.2502LS-6.50M | CUTTER BODY | 1 | |
| 2 | 34-28-51 | STOP COLLAR | 1 | |
| 3 | 30-28-51 | ACTIVATOR DISK | 1 | |
| 4 | 016-556-.218 | ACTIVATOR PIN | 2 | 2 |
| 5 | 13-20U02-18B | ACTIVATING ROD | 1 | 1 |
| 6 | 35-28-51 | FLYWHEEL ASSEMBLY | 1 | |
| 7 | 003-002 | THRUST BEARING | 1 | |
| 8 | 014-304 | THRUST WASHER | 1 | |
| 9 | 36-28-51 | SPRING SPACER | 1 | |
| 10 | 017-088 | SPRING | 1 | |
| 11 | 026-009 | RETAINING RING, CRESCENT, C-23ST | 1 | 1 |
| 12 | 202810-02 | SHANK, WELDON, $\varnothing .75$ in | 1 | |
| 13 | 203020-02 | SHEAR PIN | 1 | 3 |
| 14 | 015-112 | O-RING | 1 | 1 |
| 15 | 2020U12B | PIVOT PIN, HALF-MOON, 0.0625 | 1 | 1 |
| 16 | C25-X.XXM | CUTTER BLADE | 1 | |

BLADES SOLD SEPARATELY



Steiner Technologies, Inc.
180 Perinton Pkwy
Fairport, NY 14450
(P) 888-327-1949

ENDUSER: Steiner
DRAWN BY: M.Hoyt
DWG DATE: 11/11/2019



SCALE 1:2 DWG SIZE: A SHEET: 1 OF 2
TITLE:
Autofacer - 55.2502LS

SERIAL NO.
AF25-6.50

REV.
A

4

3

2

1

| REVISIONS | | | | |
|-----------|------|-------------|-------|----------|
| ZONE | REV. | DESCRIPTION | DATE | APPROVED |
| | A | RELEASED | 11/19 | M.Hoyt |

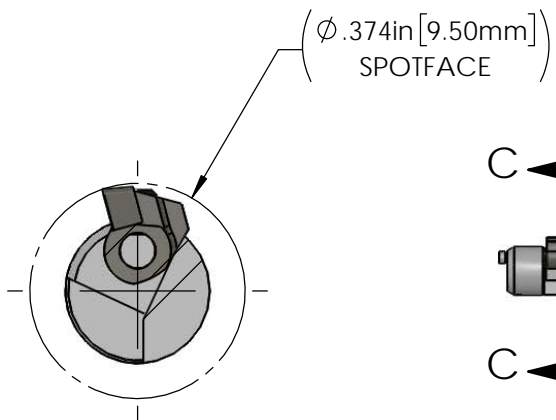

SECTION C-C
SCALE 3 : 1

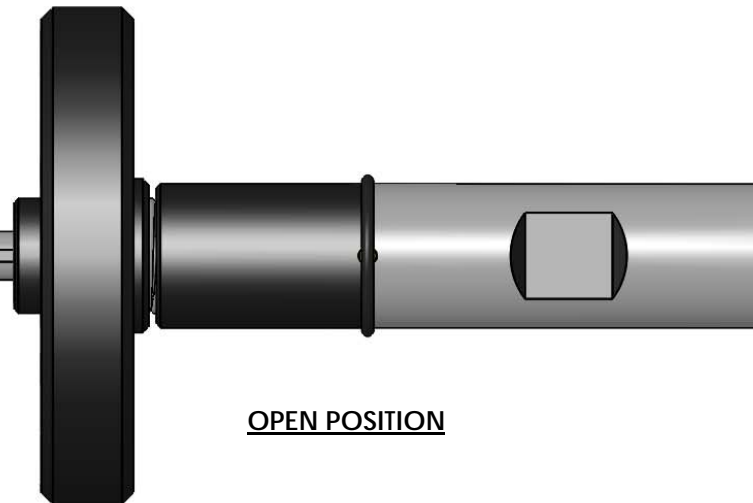
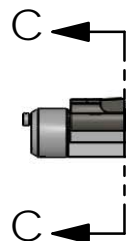

OPEN POSITION

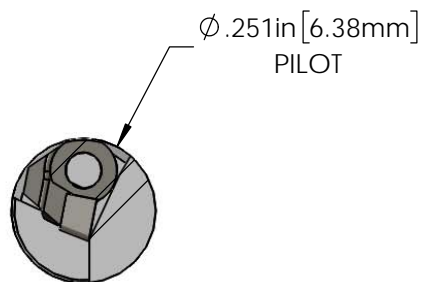

SECTION D-D
SCALE 3 : 1

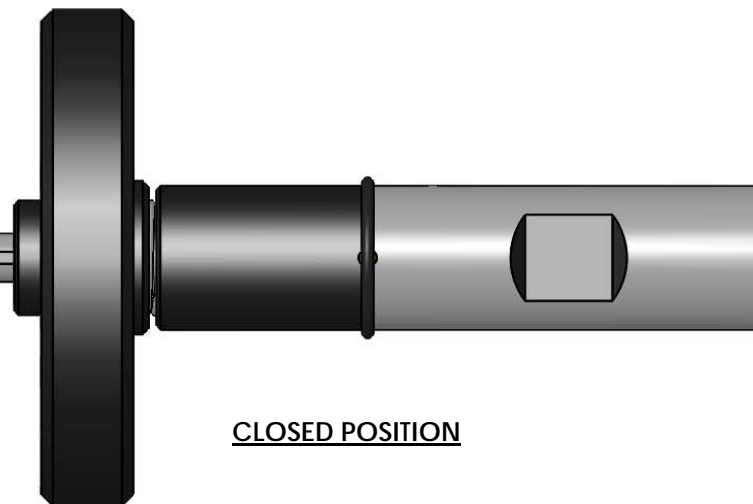
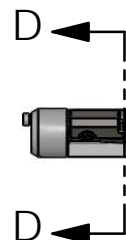

CLOSED POSITION

STEINER

Steiner Technologies, Inc.
180 Perinton Pkwy
Fairport, NY 14450
(P) 888-327-1949

ENDUSER: Steiner
DRAWN BY: M.Hoyt
DWG DATE: 11/11/2019



SCALE 1:2 DWG SIZE: A SHEET: 2 OF 2
TITLE: Autofacer - 55.2502LS

SERIAL NO. AF25-6.50

REV. A

4

3

2

1