

NOTES:

- 1. PILOT HOLE DIAMETER TO BE HELD TO: $\varnothing 6.50 \pm 0.076$ mm
- 2. APPROXIMATE TOOL WEIGHT: 1.071 LBS
- 3. CUTTER BLADE SHOWN FOR REFERENCE ONLY, TOOL DESIGNED TO WORK WITH CB25-~~X~~.XXM BLADES.

REVISIONS				
ZONE	REV.	DESCRIPTION	DATE	APPROVED
	A	RELEASED	11/19	M.Hoyt

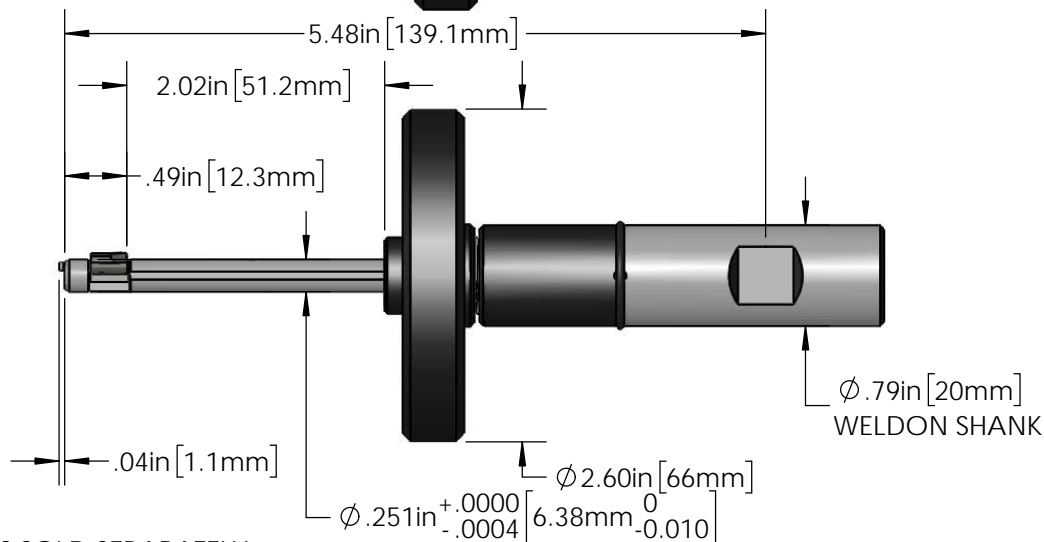
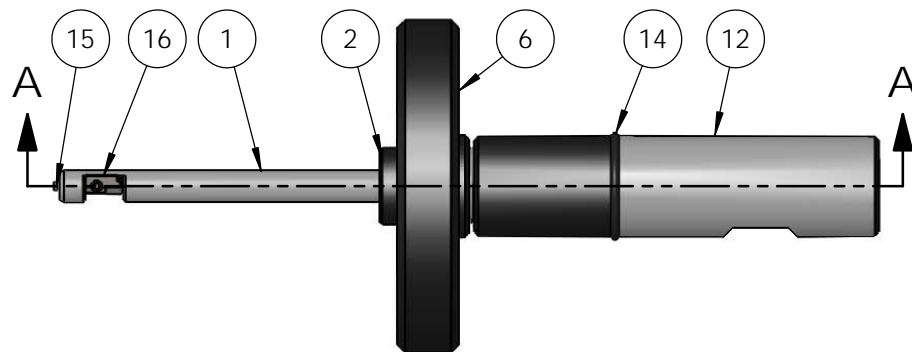
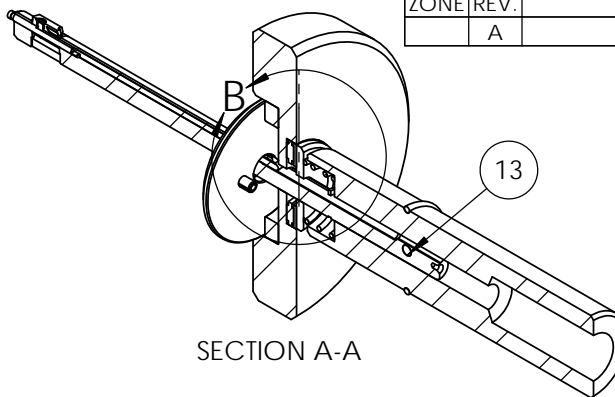
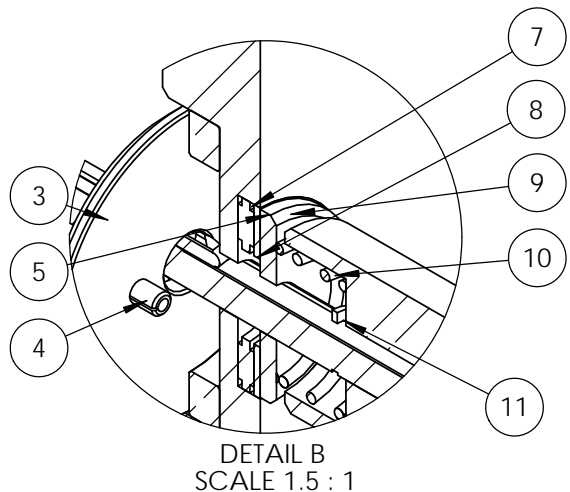

ITEM NO.	PART NUMBER	DESCRIPTION	OPEN /QTY.	Spare Qty
1	39.2502LS-6.50M	CUTTER BODY	1	
2	34-28-51	STOP COLLAR	1	
3	30-28-51	ACTIVATOR DISK	1	
4	016-556-.218	ACTIVATOR PIN	2	2
5	13-20U02-18B	ACTIVATING ROD	1	1
6	35-28-51	FLYWHEEL ASSEMBLY	1	
7	003-002	THRUST BEARING	1	
8	014-304	THRUST WASHER	1	
9	36-28-51	SPRING SPACER	1	
10	017-088	SPRING	1	
11	026-009	RETAINING RING, CRESCENT, C-23ST	1	1
12	202810-03	SHANK, WELDON, $\varnothing 20$ mm	1	
13	203020-02	SHEAR PIN	1	3
14	015-112	O-RING	1	1
15	2020U12B	PIVOT PIN, HALF-MOON, 0.0625	1	1
16	C25-X.XXM	CUTTER BLADE	1	

BLADES SOLD SEPARATELY



Steiner Technologies, Inc.
180 Perinton Pkwy
Fairport, NY 14450
(P) 888-327-1949

ENDUSER: Steiner
DRAWN BY: M.Hoyt
DWG DATE: 11/11/2019



SCALE 1:2 DWG SIZE: A SHEET: 1 OF 2
TITLE:
Autofacer - 55.2502MLS

SERIAL NO.
AF25-6.50M

REV.
A

4

3

2

1

REVISIONS				
ZONE	REV.	DESCRIPTION	DATE	APPROVED
	A	RELEASED	11/19	M.Hoyt

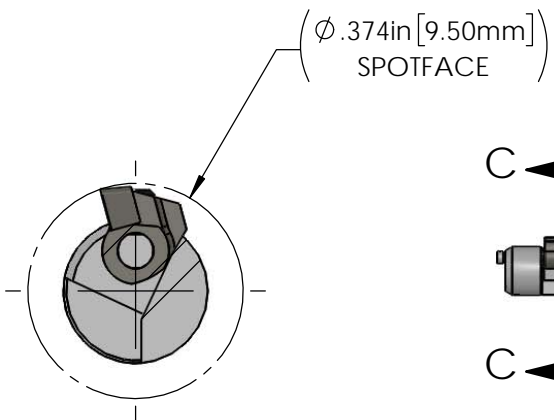

SECTION C-C
SCALE 3 : 1

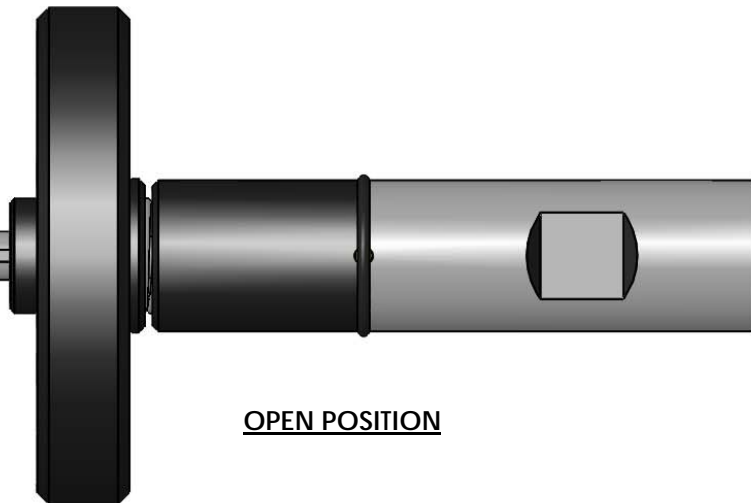
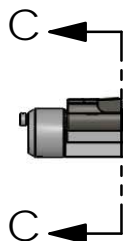

OPEN POSITION

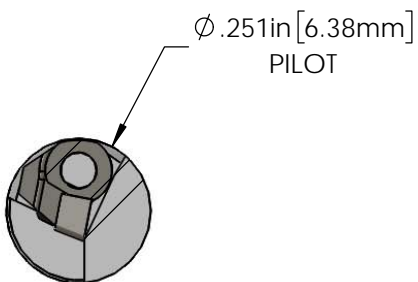

SECTION D-D
SCALE 3 : 1

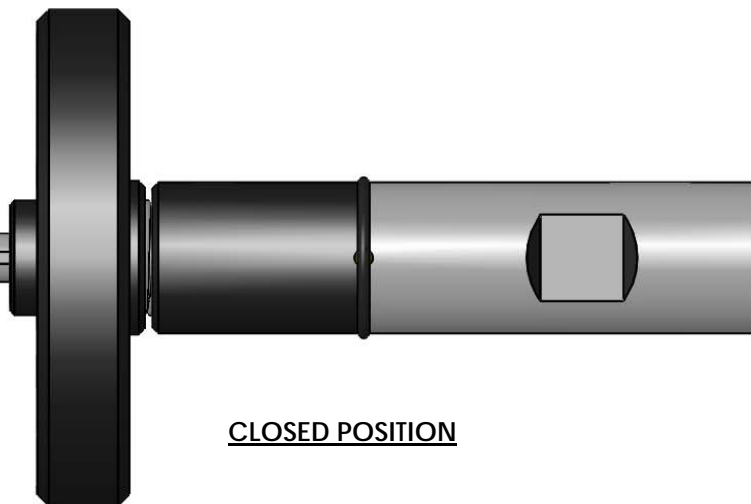
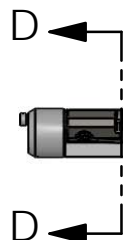

CLOSED POSITION

STEINER

Steiner Technologies, Inc.
180 Perinton Pkwy
Fairport, NY 14450
(P) 888-327-1949

ENDUSER: Steiner
DRAWN BY: M.Hoyt
DWG DATE: 11/11/2019



SCALE 1:2 DWG SIZE: A SHEET: 2 OF 2
TITLE: Autofacer - 55.2502MLS

SERIAL NO. AF25-6.50M
REV. A

4

3

2

1