

NOTES:

- 1. PILOT HOLE DIAMETER TO BE HELD TO: $\varnothing 8.00 \pm 0.076 \text{mm}$
- 2. APPROXIMATE TOOL WEIGHT: 1.047 LBS
- 3. CUTTER BLADE SHOWN FOR REFERENCE ONLY, TOOL DESIGNED TO WORK WITH CB31-X.XXM BLADES.

REVISIONS				
ZONE	REV.	DESCRIPTION	DATE	APPROVED
	A	RELEASED	1/20	M.Hoyt

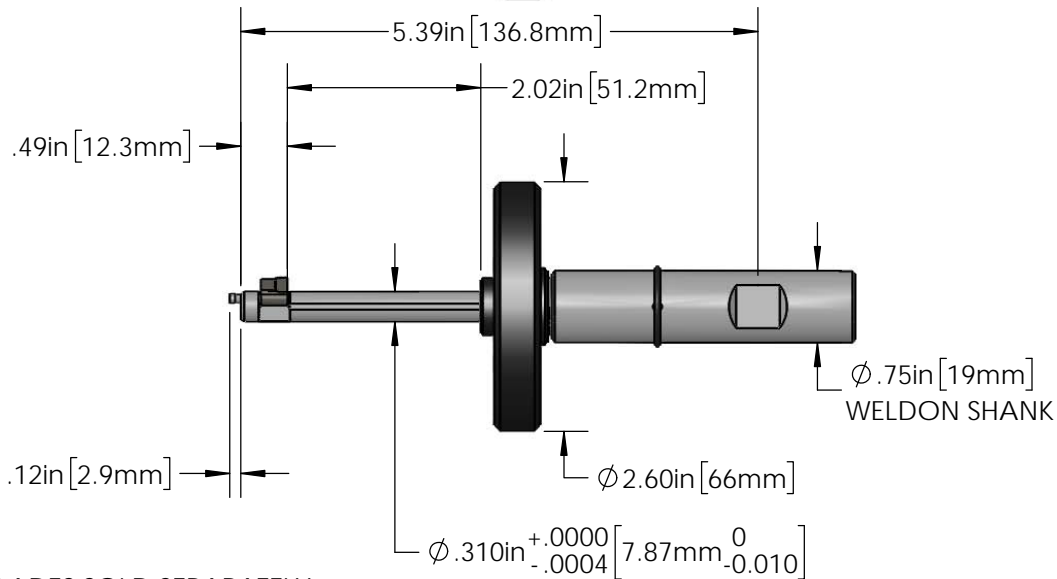
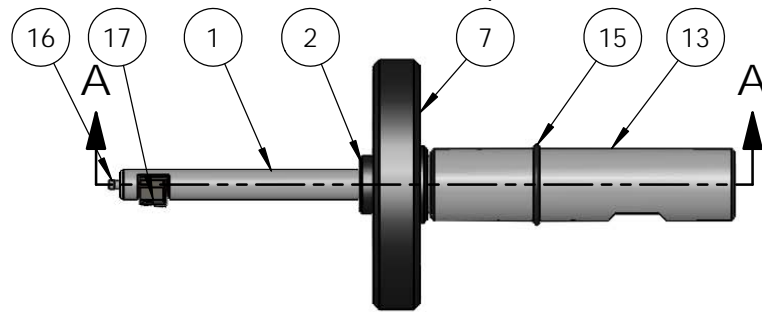
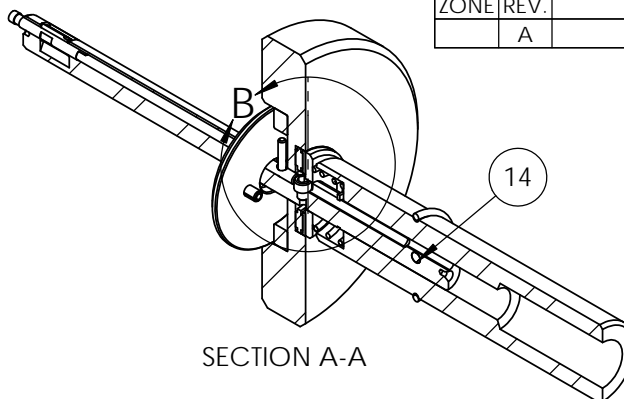
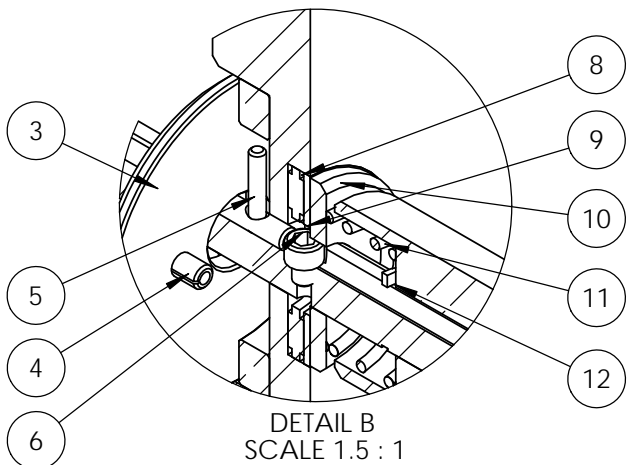

ITEM NO.	PART NUMBER	DESCRIPTION	OPEN /QTY.	Spare Qty
1	39.3102L-8.00M	CUTTER BODY	1	
2	34-31-51	STOP COLLAR	1	
3	30-31-51	ACTIVATOR DISK	1	
4	016-556-.218	ACTIVATOR PIN	2	2
5	13-2802-52	ACTIVATING ROD	1	1
6	028-177-M	SHCS, #2-56 X 3/32	1	
7	35-31-51	FLYWHEEL ASSEMBLY	1	
8	003-002	THRUST BEARING	1	
9	014-304	THRUST WASHER	1	
10	36-31-51	SPRING SPACER	1	
11	017-088	SPRING	1	
12	026-008	RETAINING RING, CRESCENT, C-28ST	1	1
13	203110-02	SHANK, WELDON, $\varnothing .75 \text{in}$	1	
14	203020-02	SHEAR PIN	1	3
15	015-112	O-RING	1	1
16	202812	PIVOT PIN, 0.0935	1	1
17	CB31-X.XXM	CUTTER BLADE	1	

BLADES SOLD SEPARATELY



Steiner Technologies, Inc.
 180 Perinton Pkwy
 Fairport, NY 14450
 (P) 888-327-1949

ENDUSER: Steiner
 DRAWN BY: M.Hoyt
 DWG DATE: 1/8/2020



SCALE 1:2 DWG SIZE: A SHEET: 1 OF 2
 TITLE: Autofacer - 55.3102L

SERIAL NO. AF31-8.00

REV. A

4

3

2

1

REVISIONS				
ZONE	REV.	DESCRIPTION	DATE	APPROVED
	A	RELEASED	1/20	M.Hoyt

(\varnothing .630in [16mm])
SPOTFACE

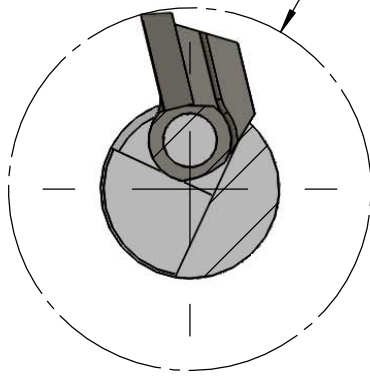

SECTION C-C
SCALE 3 : 1

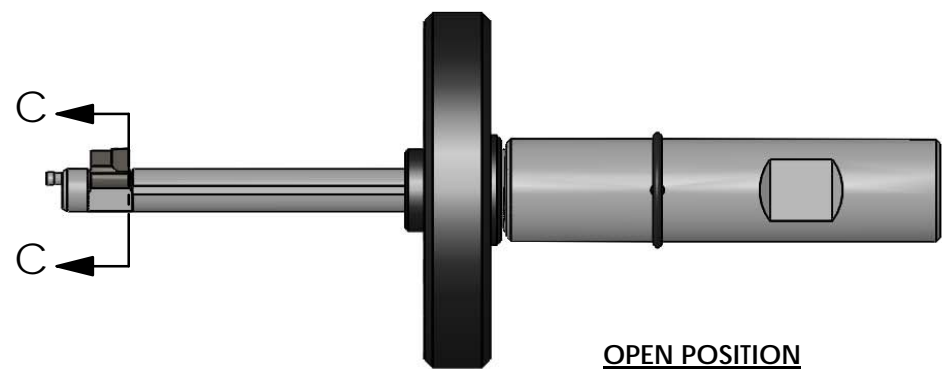

OPEN POSITION

\varnothing .310in [7.87mm]
PILOT

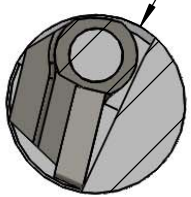

SECTION D-D
SCALE 3 : 1

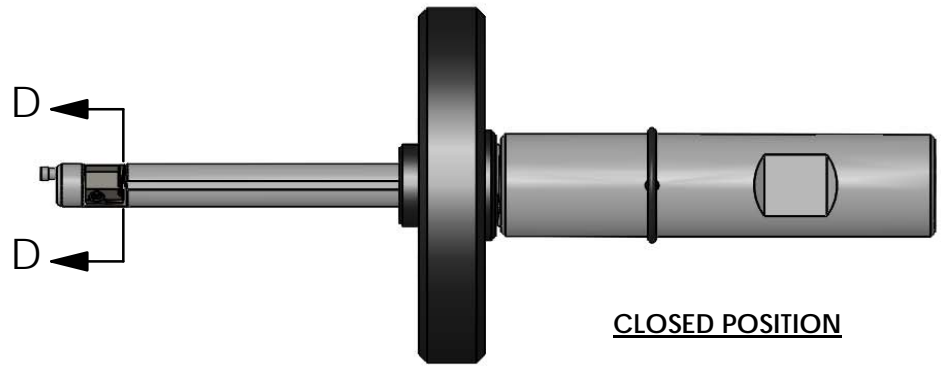

CLOSED POSITION

STEINER

Steiner Technologies, Inc.
180 Perinton Pkwy
Fairport, NY 14450
(P) 888-327-1949

ENDUSER: Steiner

DRAWN BY: M.Hoyt
DWG DATE: 1/8/2020



SCALE 1:2

DWG SIZE: A

SHEET: 2 OF 2

SERIAL NO.

TITLE:

Autofacer - 55.3102L

AF31-8.00

REV.

A

4

3

2

1