

- NOTES:
1. PILOT HOLE DIAMETER TO BE HELD TO: $\varnothing .433 +0.003/-0.003$
 2. APPROXIMATE TOOL WEIGHT: 1.119 LBS
 3. CUTTER BLADE SHOWN FOR REFERENCE ONLY, TOOL DESIGNED TO WORK WITH CB40-XX.XXM BLADES.

REVISIONS				
ZONE	REV.	DESCRIPTION	DATE	APPROVED
	A	RELEASED	1/20	M.Hoyt

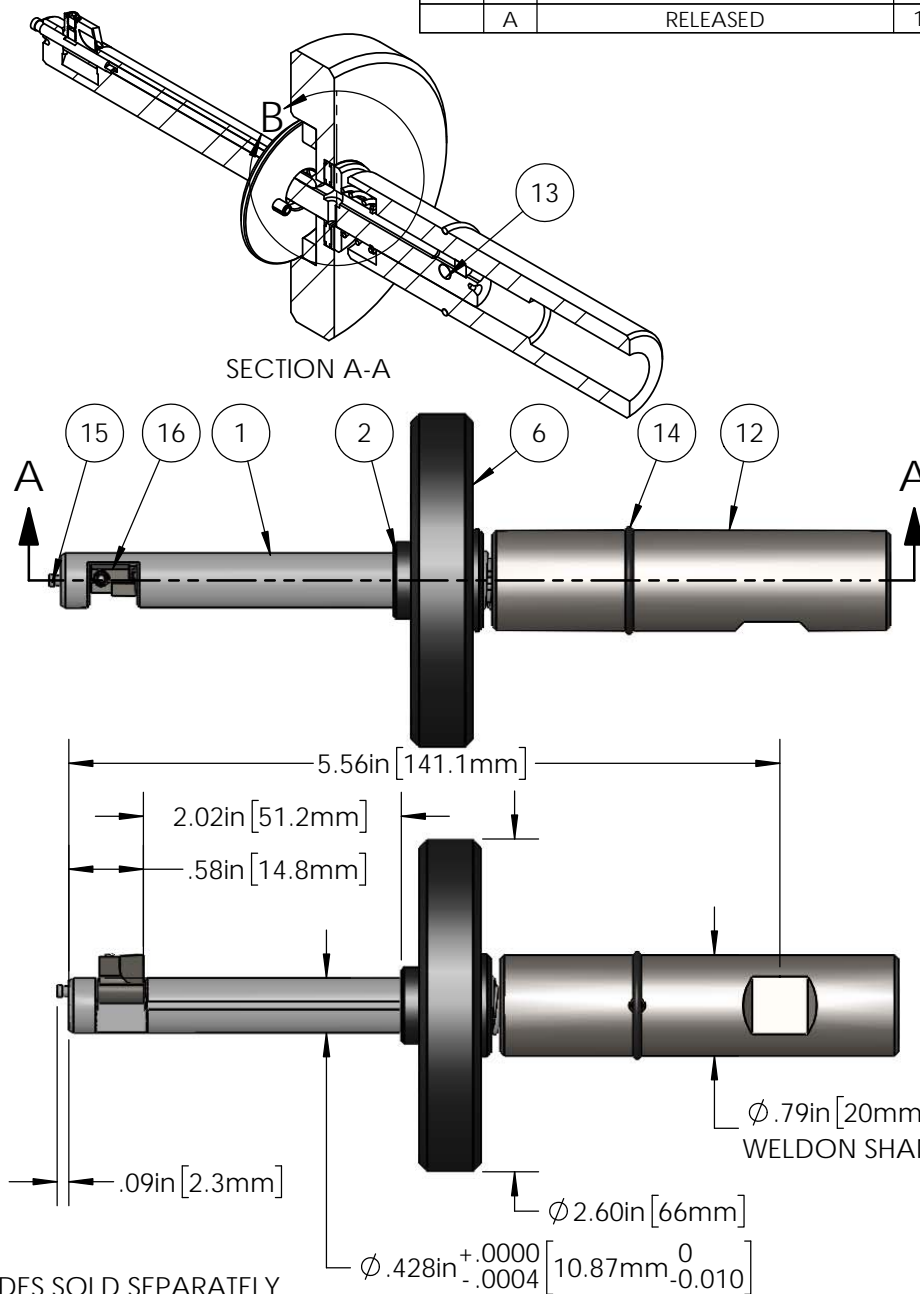
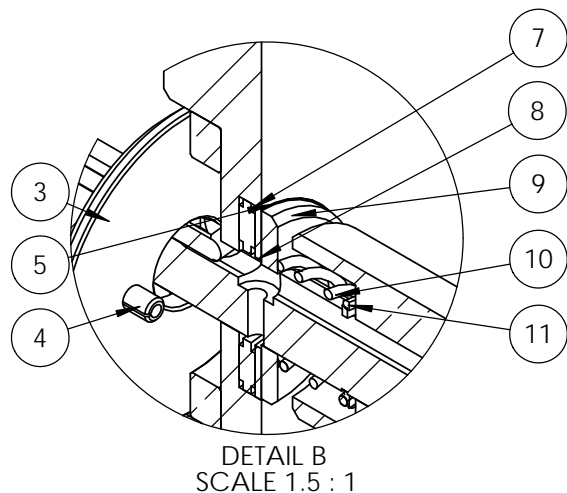

ITEM NO.	PART NUMBER	DESCRIPTION	OPEN /QTY.	Spare Qty
1	39.4002LS-11.00M	CUTTER BODY	1	
2	34-38-51	STOP COLLAR	1	
3	30-38-51	ACTIVATOR DISK	1	
4	016-556-.218	ACTIVATOR PIN	2	2
5	13-38S02-51	ACTIVATING ROD	1	1
6	35-38-51	FLYWHEEL ASSEMBLY	1	
7	003-002	THRUST BEARING	1	
8	014-304	THRUST WASHER	1	
9	36-38-51	SPRING SPACER	1	
10	017-004	SPRING	1	
11	026-101	RETAINING RING, EXTERNAL, SH-34ST	1	1
12	204010-03	SHANK, WELDON, $\varnothing 20\text{mm}$	1	
13	204020-02	SHEAR PIN	1	3
14	015-112	O-RING	1	1
15	2040S12	PIVOT PIN, 0.0935	1	1
16	CB40-X.XXM	CUTTER BLADE	1	
17	66-47-25	COOLANT STOP KEY	1	

BLADES SOLD SEPARATELY



Steiner Technologies, Inc.
180 Perinton Pkwy
Fairport, NY 14450
(P) 888-327-1949

ENDUSER: Steiner
DRAWN BY: M.Hoyt
DWG DATE: 1/14/2020



SCALE 1:2 DWG SIZE: A SHEET: 1 OF 2
TITLE:
Autofacer - 55.4002MLS

SERIAL NO.
AF40-11.00M

REV.
A

4

3

2

1

REVISIONS				
ZONE	REV.	DESCRIPTION	DATE	APPROVED
	A	RELEASED	1/20	M.Hoyt

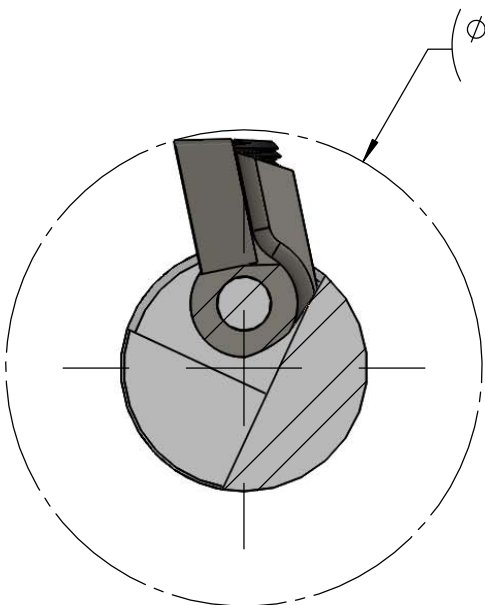

SECTION C-C
SCALE 3 : 1

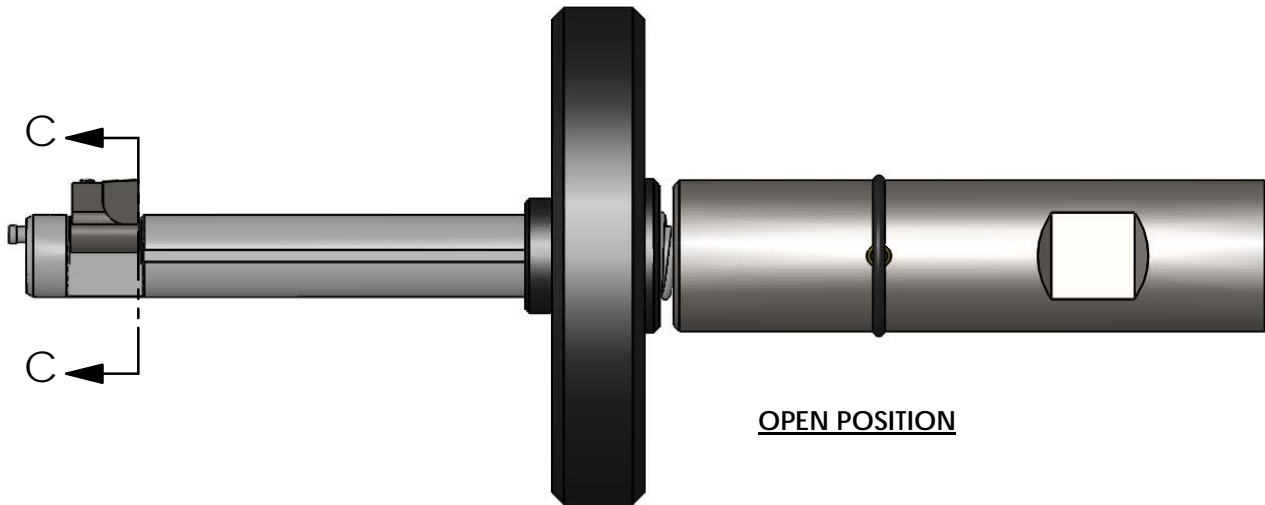

OPEN POSITION

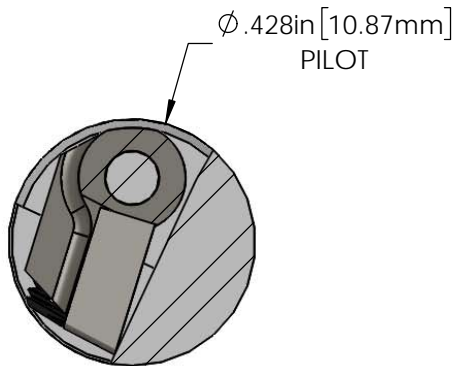

SECTION D-D
SCALE 3 : 1

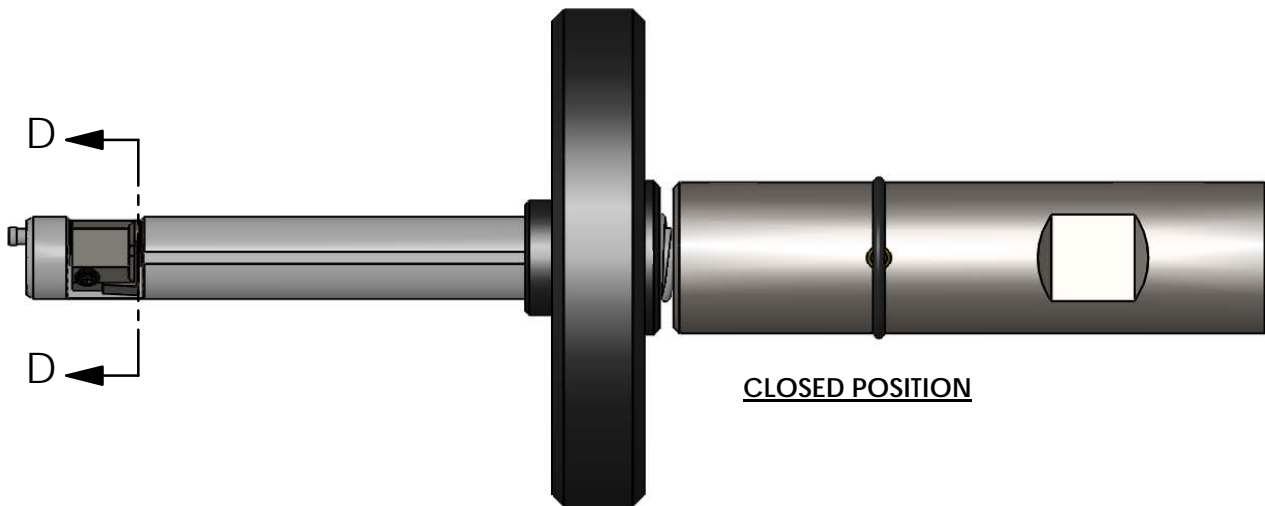

CLOSED POSITION

STEINER

Steiner Technologies, Inc.
180 Perinton Pkwy
Fairport, NY 14450
(P) 888-327-1949

ENDUSER: Steiner
DRAWN BY: M.Hoyt
DWG DATE: 1/14/2020



SCALE 1:2 | DWG SIZE: A | SHEET: 2 OF 2
TITLE: Autofacer - 55.4002MLS

SERIAL NO.
AF40-11.00M

REV.
A

4

3

2

1