

- NOTES:
1. PILOT HOLE DIAMETER TO BE HELD TO:  $\varnothing .531 +0.003/-0.003$
  2. APPROXIMATE TOOL WEIGHT: 1.140 LBS
  3. CUTTER BLADE SHOWN FOR REFERENCE ONLY, TOOL DESIGNED TO WORK WITH CB53-XX.XXM BLADES.

REVISIONS				
ZONE	REV.	DESCRIPTION	DATE	APPROVED
	A	RELEASED	1/20	M.Hoyt

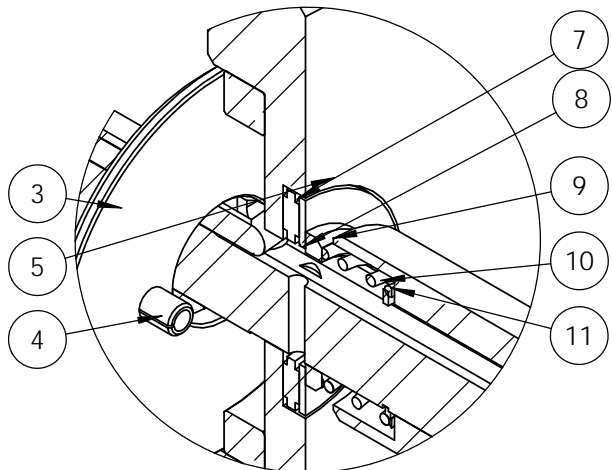

DETAIL B  
SCALE 1.5 : 1

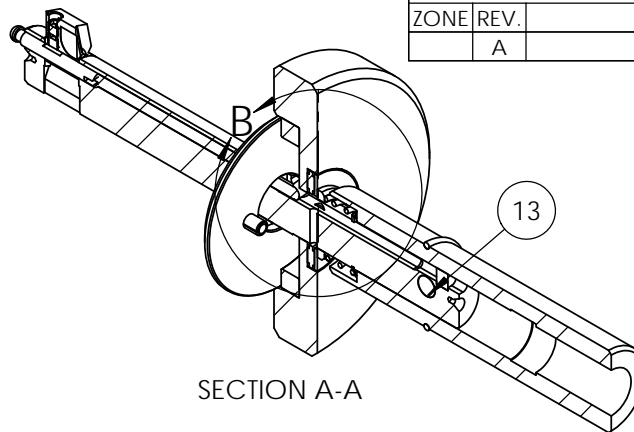

SECTION A-A

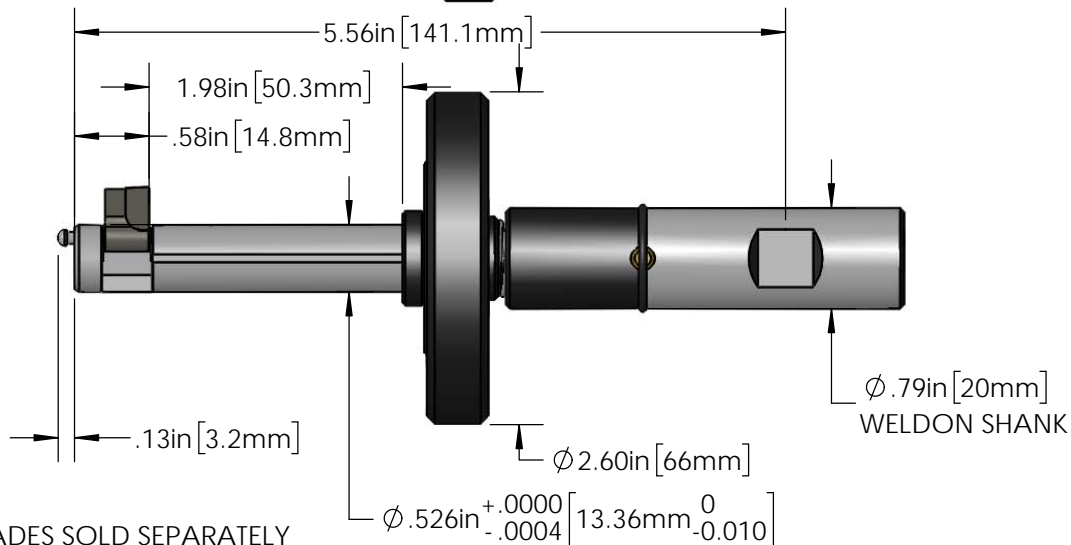
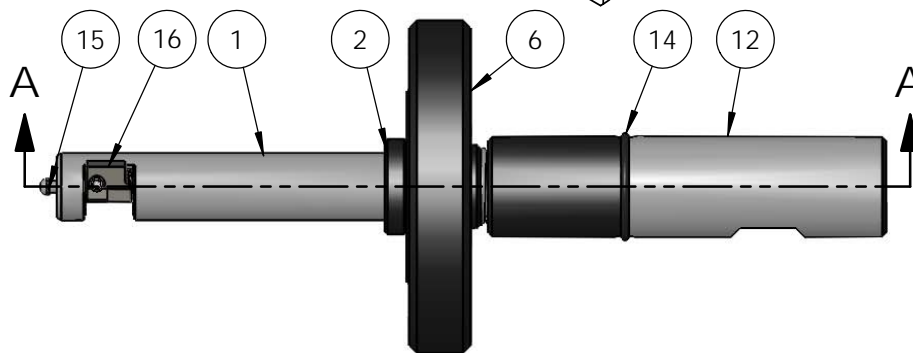

ITEM NO.	PART NUMBER	DESCRIPTION	OPEN /QTY.	Spare Qty
1	39.5302LS-13.50M	CUTTER BODY	1	
2	34-53-51	STOP COLLAR	1	
3	30-53-51	ACTIVATOR DISK	1	
4	016-511	ACTIVATOR PIN	2	2
5	13-50S02-51	ACTIVATING ROD	1	1
6	35-50-51	FLYWHEEL ASSEMBLY	1	
7	003-003	THRUST BEARING	1	
8	014-306	THRUST WASHER	1	
9	36-47-51	SPRING SPACER	1	
10	017-088	SPRING	1	
11	026-102	RETAINING RING, EXTERNAL, SH-46ST	1	1
12	205010-03	SHANK, WELDON, $\varnothing 20\text{mm}$	1	
13	205020-02	SHEAR PIN	1	3
14	015-112	O-RING	1	1
15	204012	PIVOT PIN, 0.1250	1	1
16	CB53-X.XXM	CUTTER BLADE	1	
17	66-53-25	COOLANT STOP KEY	1	

BLADES SOLD SEPARATELY



Steiner Technologies, Inc.  
180 Perinton Pkwy  
Fairport, NY 14450  
(P) 888-327-1949

ENDUSER: Steiner  
DRAWN BY: M.Hoyt  
DWG DATE: 1/15/2020



SCALE 1:2 DWG SIZE: A SHEET: 1 OF 2  
TITLE:  
Autofacer - 55.5302MLS

SERIAL NO.  
AF53-13.50M

REV.  
A

4

3

2

1

REVISIONS				
ZONE	REV.	DESCRIPTION	DATE	APPROVED
	A	RELEASED	1/20	M.Hoyt

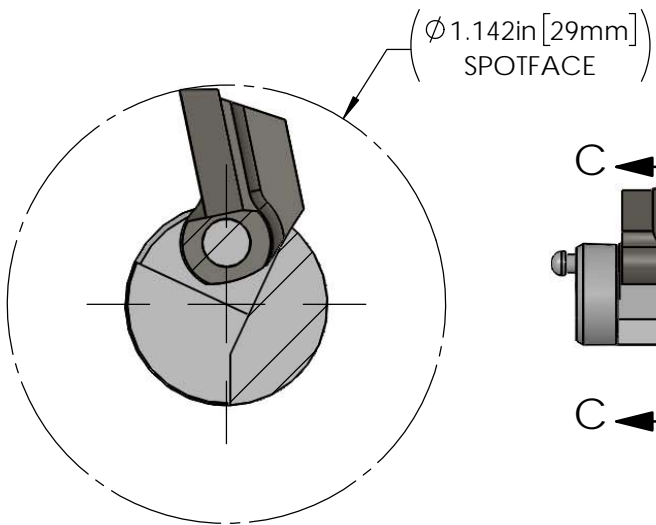

SECTION C-C  
SCALE 2 : 1

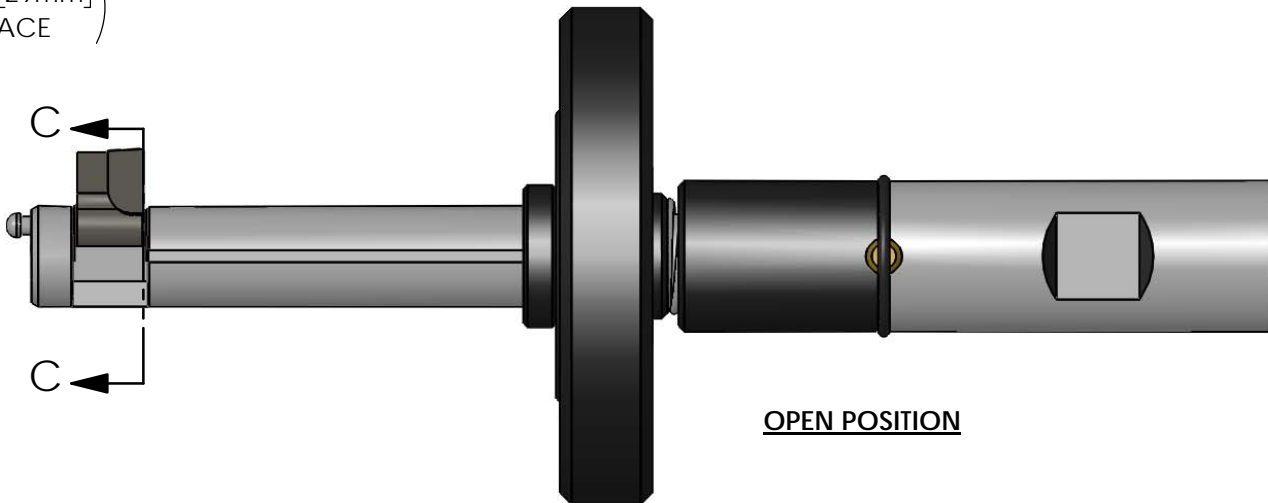

OPEN POSITION

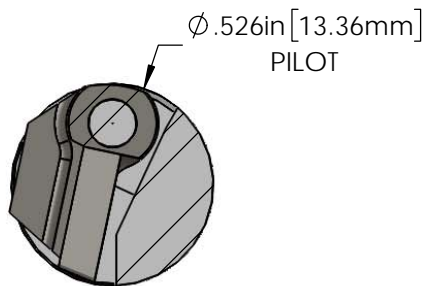

SECTION D-D  
SCALE 2 : 1

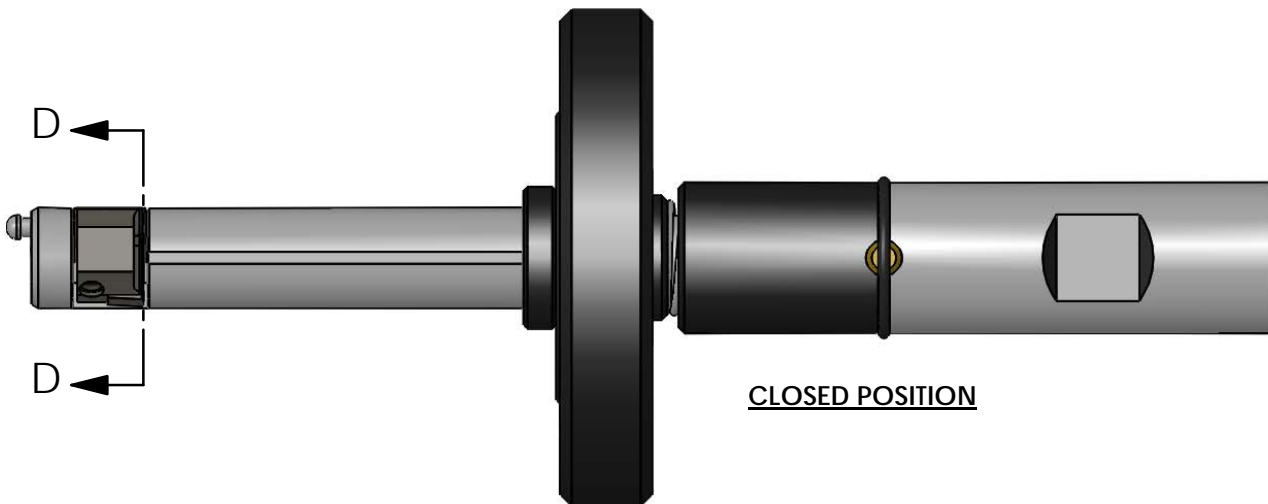

CLOSED POSITION

**STEINER**

Steiner Technologies, Inc.  
180 Perinton Pkwy  
Fairport, NY 14450  
(P) 888-327-1949

ENDUSER: Steiner

DRAWN BY: M.Hoyt  
DWG DATE: 1/15/2020



SCALE 1:2

DWG SIZE: A

SHEET: 2 OF 2

SERIAL NO.

TITLE:

Autofacer - 55.5302MLS

AF53-13.50M

REV.

A

4

3

2

1