

NOTES:

- 1. PILOT HOLE DIAMETER TO BE HELD TO: $\varnothing .610 +0.003/-0.003$
- 2. APPROXIMATE TOOL WEIGHT: 1.194 LBS
- 3. CUTTER BLADE SHOWN FOR REFERENCE ONLY, TOOL DESIGNED TO WORK WITH CB59-XX.XXM BLADES.

REVISIONS				
ZONE	REV.	DESCRIPTION	DATE	APPROVED
	A	RELEASED	1/20	M.Hoyt

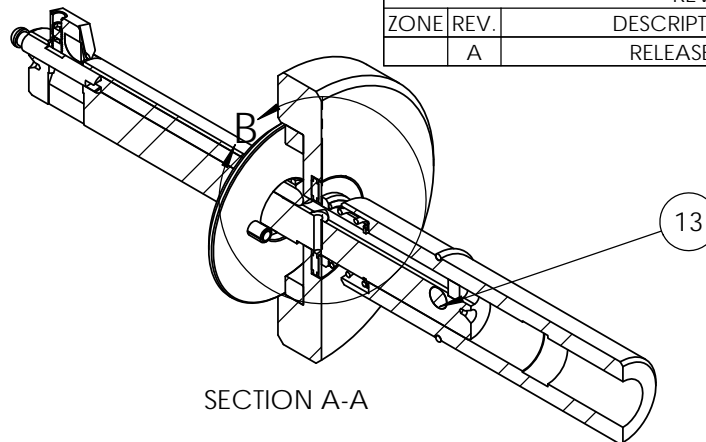

SECTION A-A

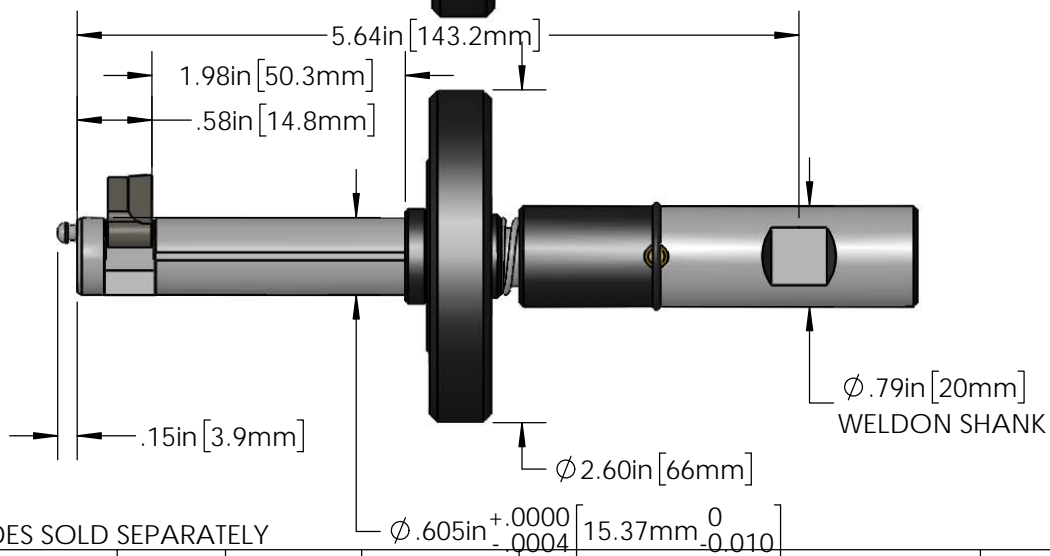
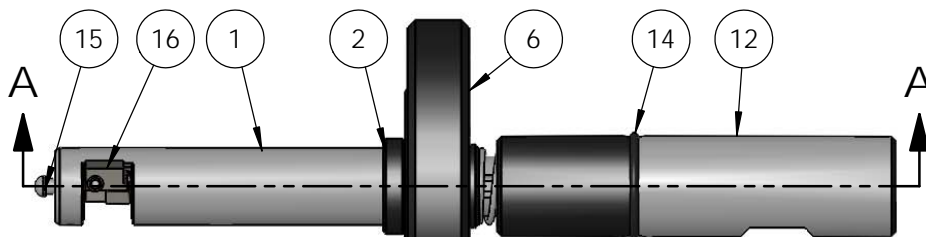

BLADES SOLD SEPARATELY

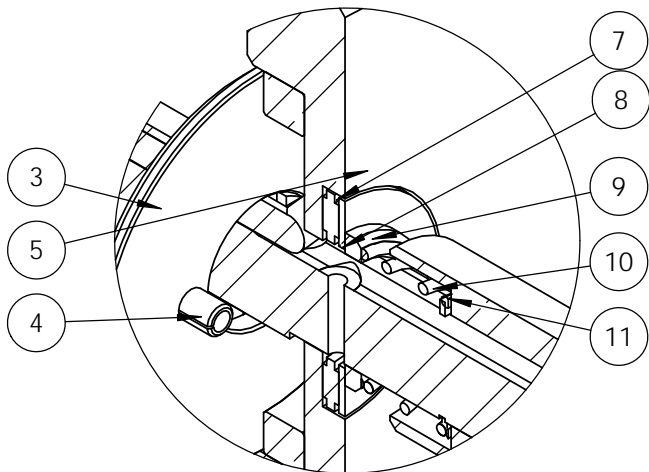

DETAIL B
SCALE 1.5 : 1

ITEM NO.	PART NUMBER	DESCRIPTION	OPEN /QTY.	Spare Qty
1	39.5902-15.50M	CUTTER BODY	1	
2	34-59-51	STOP COLLAR	1	
3	30-59-51	ACTIVATOR DISK	1	
4	016-511	ACTIVATOR PIN	2	2
5	13-5002-51	ACTIVATING ROD	1	1
6	35-50-51	FLYWHEEL ASSEMBLY	1	
7	003-003	THRUST BEARING	1	
8	014-306	THRUST WASHER	1	
9	36-47-51	SPRING SPACER	1	
10	017-088	SPRING	1	
11	026-102	RETAINING RING, EXTERNAL, SH-46ST	1	1
12	205010-03	SHANK, WELDON, $\varnothing 20mm$	1	
13	205620-02	SHEAR PIN	1	3
14	015-112	O-RING	1	1
15	12-62-20	PIVOT PIN, 0.1565	1	1
16	CB59-X.XXM	CUTTER BLADE	1	
17	66-53-25	COOLANT STOP KEY	1	

<p>Steiner Technologies, Inc. 180 Perinton Pkwy Fairport, NY 14450 (P) 888-327-1949</p>	ENDUSER: Steiner DRAWN BY: M.Hoyt DWG DATE: 1/15/2020	SCALE 1:2 DWG SIZE: A SHEET: 1 OF 2 TITLE: Autofacer - 55.5902M	SERIAL NO. AF59-15.50M	REV. A

REVISIONS				
ZONE	REV.	DESCRIPTION	DATE	APPROVED
	A	RELEASED	1/20	M.Hoyt

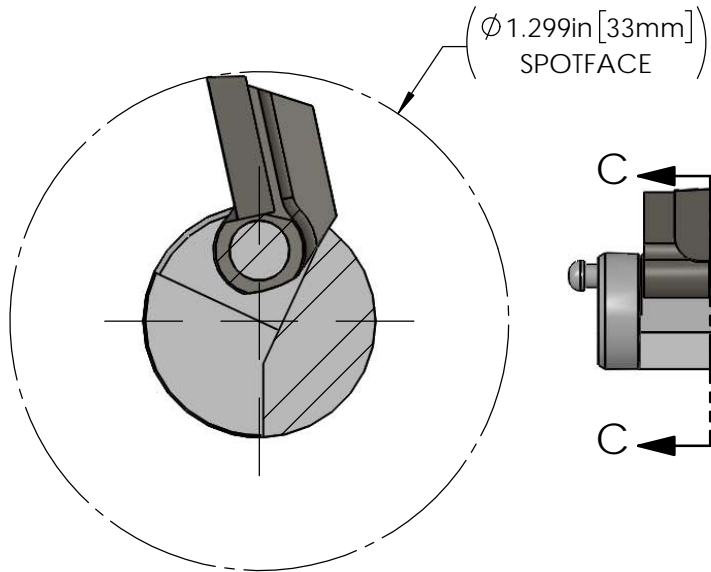

SECTION C-C
SCALE 2 : 1

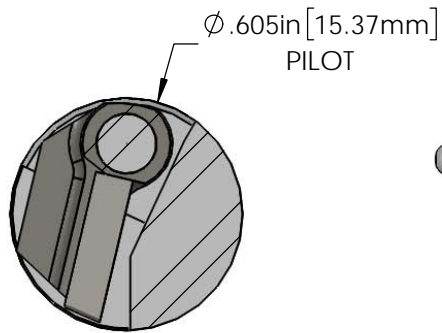

SECTION D-D
SCALE 2 : 1

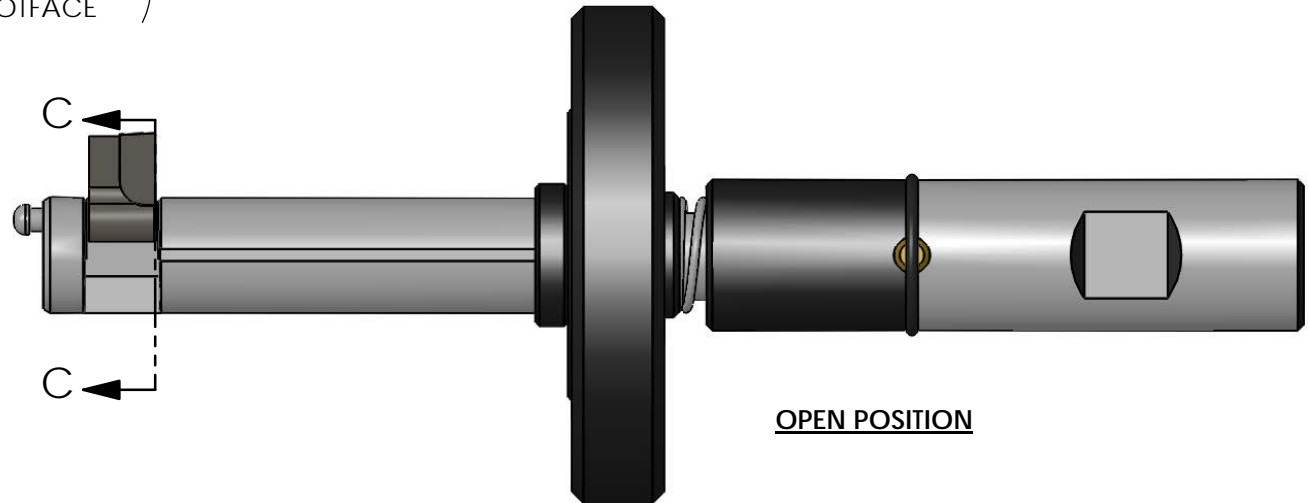

OPEN POSITION

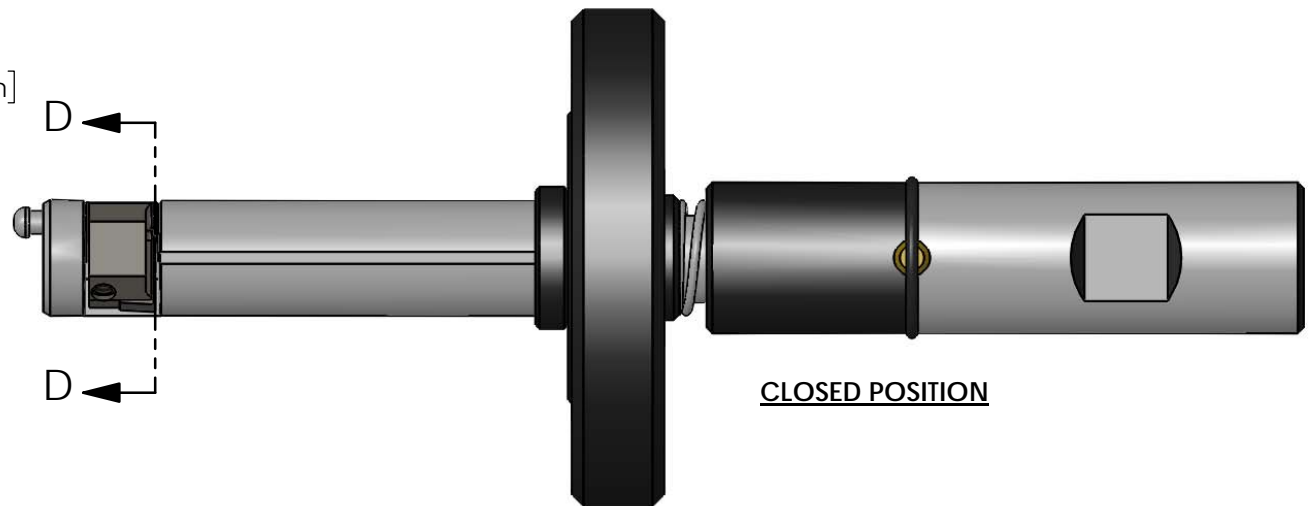

CLOSED POSITION

STEINER

Steiner Technologies, Inc.
180 Perinton Pkwy
Fairport, NY 14450
(P) 888-327-1949

ENDUSER: Steiner
DRAWN BY: M.Hoyt
DWG DATE: 1/15/2020



SCALE 1:2 DWG SIZE: A SHEET: 2 OF 2
TITLE:
Autofacer - 55.5902M

SERIAL NO.
AF59-15.50M
REV.
A