

4

3

2

1

REVISIONS				
ZONE	REV.	DESCRIPTION	DATE	APPROVED
	A	RELEASED	1/20	M.Hoyt

C

C

B

B

A

A

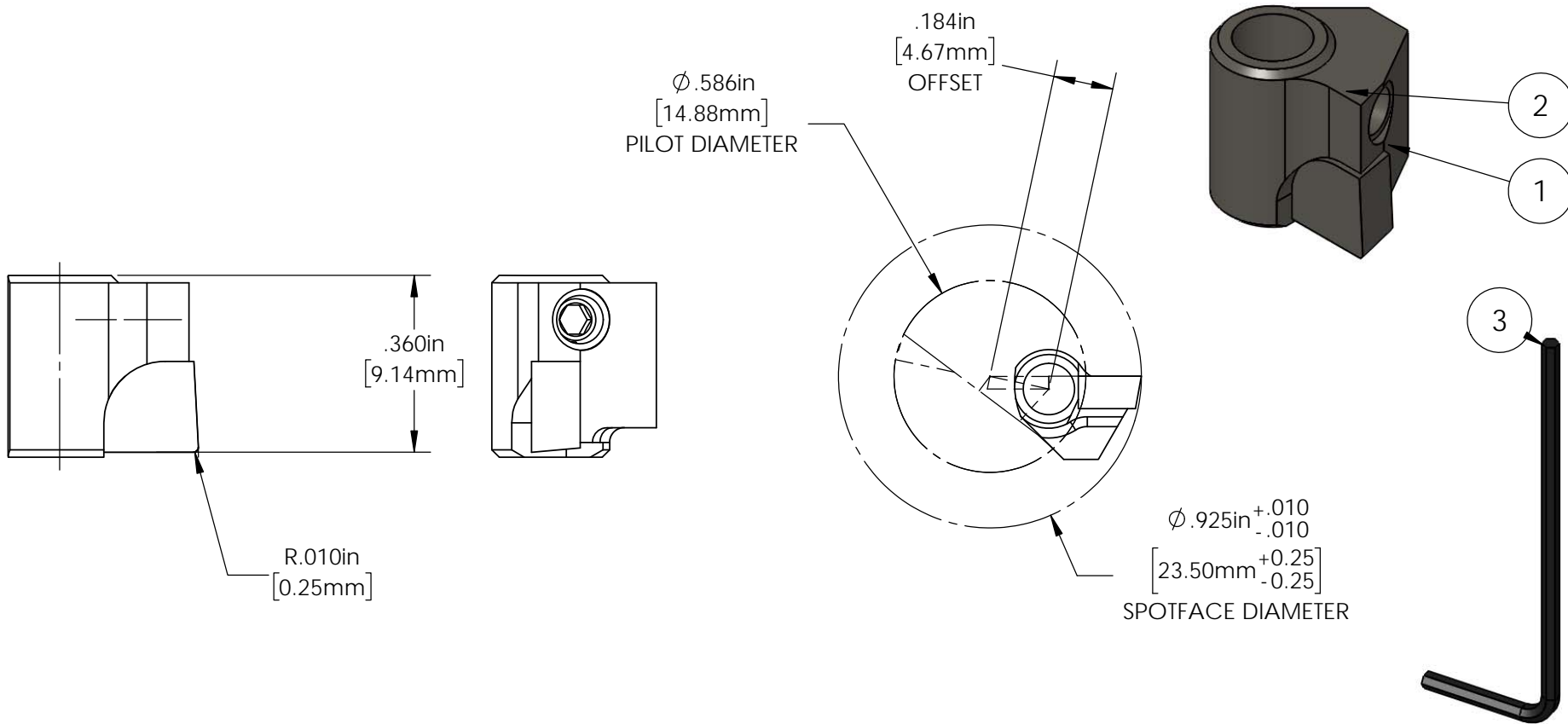

ITEM NO.	PART NUMBER	DESCRIPTION	QTY.
1	2050	CUTTER BLADE BLANK	1
2	029-083	SOCKET SET SCREW, M3 X 0.5 X 3	1
3	031-15M	HEX ALLEN WRENCH, 1.5mm	1
4	2050	CARBIDE BLANK	1

CARBIDE: **MG**  
 COATING: **NONE**

THIS DRAWING IS THE CONFIDENTIAL AND EXCLUSIVE PROPERTY OF STEINER TECHNOLOGIES, INC. AND MAY NOT BE COPIED, REPRODUCED, OR DISCLOSED IN ANY WAY, WHATSOEVER TO ANYONE WITHOUT THE EXPRESS WRITTEN PERMISSION OF R. STEINER TECHNOLOGIES, INC. UNLAWFUL DISCLOSURE MAY RESULT IN PROSECUTION

UNLESS OTHERWISE SPECIFIED DIMENSIONS ARE IN INCHES  
 TOLERANCES UNLESS SPECIFIED  
 X.X ±0.020 X.XXX ±0.005 ANGLES ±0.5°  
 X.XX ±0.010 X.XXXX ±0.0005  
 INTERPRET TO ASME Y14.5M-1994

DRAWN BY: M.Hoyt  
 DWG DATE: 1/15/2020  
 ENDUSER: Steiner  
 FINISH: NONE  
 MATERIAL: 4140  
 HT:

**STEINER**  
 Steiner Technologies, Inc.  
 180 Perinton Pkwy  
 Fairport, NY 14450  
 (P) 888-327-1949  
 TITLE:  
 CUTTER BLADE 23.5 +0.25/-0.25

SCALE 5:1 DWG SIZE A REV. A  
 SHEET: 2 OF 2  
 DRAWING NO.  
**CB59-23.50M**

4

3

2

1