

Modular Front Counterboring

Ordering Examples:

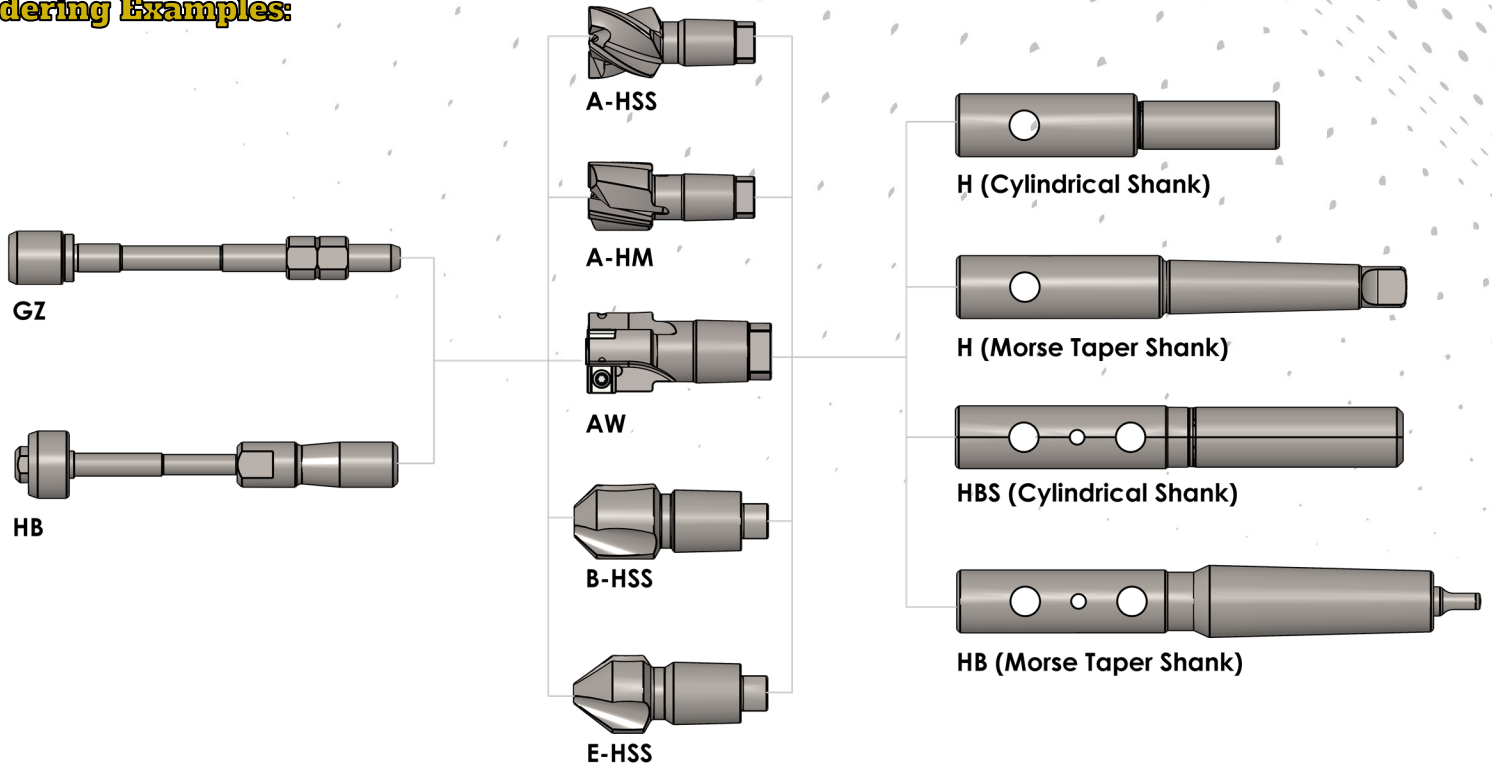

Ordering Example for counterbore with **Cone size = 3**

- Counterbore HSS D=20mm A200301**
- Pilot Set D=8mm GZ1300800**
- Holder with Shank MK3 H1303**
- Extractor H830**

Counterbores with pilots can be locked in the holder. (e.g. in machining centers) by use of HB-/HBS- holders, HB-pilots and extractor closer HB.

All Parts of the Same Cone Size Can Be Combined

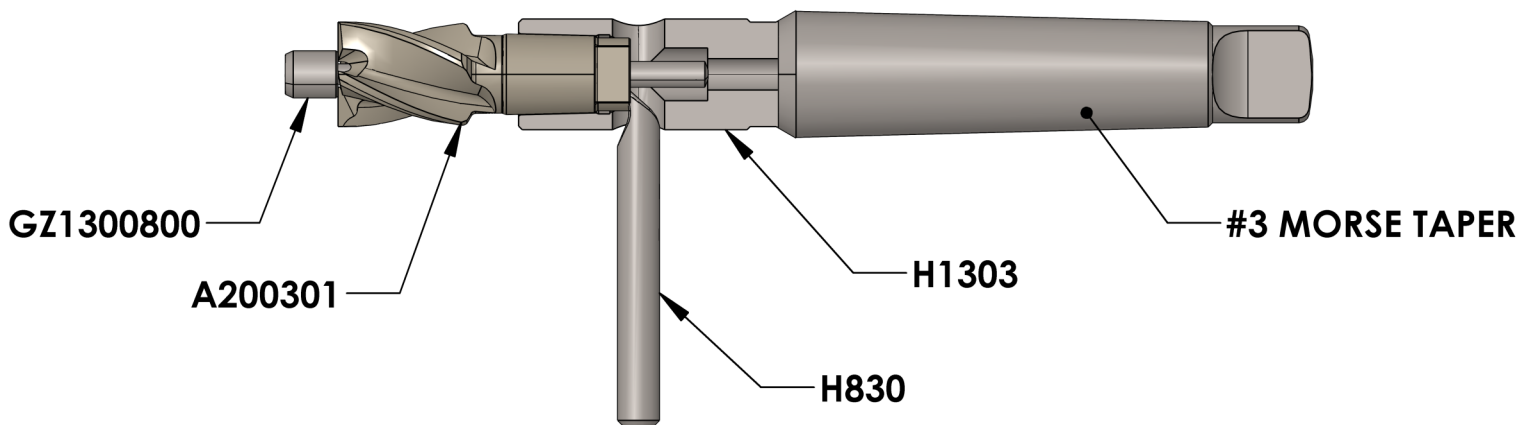

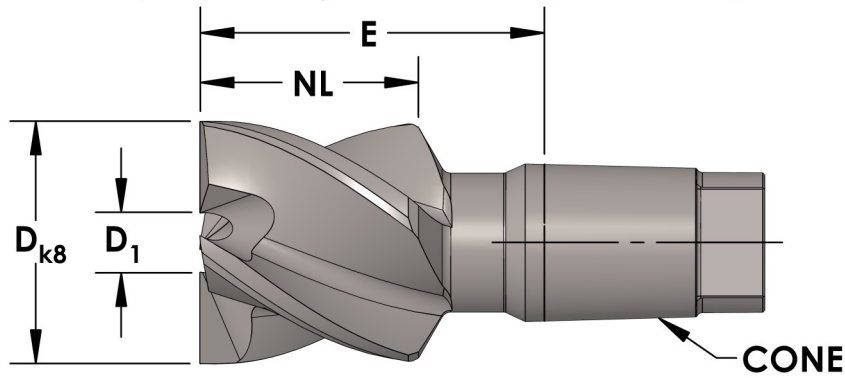

Counterbore A-HSS

A-HSS															
D	Cone Size	Order Number	D ₁	D	Cone Size	Order Number	D ₁	D	Cone Size	Order Number	D ₁	D	Cone Size	Order Number	D ₁
4.5	00	A045001	1.7	14.3	1	A143101	3.0	28.0	4	A280401	6.0	48.0	5.5	A480551	9.0
4.8	00	A048001	1.7	14.5	1	A145101	3.0	28.5	4	A285401	6.0	49.0	5.5	A490551	9.0
5.0	00	A050001	1.7	14.5	2	A145201	4.0	29.0	4	A290401	6.0	50.0	5.5	A500551	9.0
5.5	00	A055001	1.7	15.0	1	A150101	3.0	30.0	4	A300401	6.0	51.0	5.5	A510551	9.0
5.8	01	A058011	2.0	15.0	2	A150201	4.0	31.0	4	A310401	6.0	52.0	5.5	A520551	9.0
5.9	01	A059011	2.0	15.5	2	A155201	4.0	32.0	4	A320401	6.0	53.0	5.5	A530551	9.0
6.0	01	A060011	2.0	16.0	1	A160101	3.0	33.0	4	A330401	6.0	54.0	5.5	A540551	9.0
6.3	01	A063011	2.0	16.0	2	A160201	4.0	34.0	5	A340501	8.0	55.0	5.5	A550551	9.0
6.4	01	A064011	2.0	16.5	1	A165101	3.0	35.0	5	A350501	8.0	56.0	5.5	A560551	9.0
6.5	01	A065011	2.0	16.5	2	A165201	4.0	36.0	5	A360501	8.0	57.0	5.5	A570551	9.0
6.8	01	A068011	2.0	17.0	2	A170201	4.0	37.0	5	A370501	8.0	58.0	6	A580601	10.0
7.0	02	A070021	2.5	17.5	2	A175201	4.0	38.0	5	A380501	8.0	59.0	6	A590601	10.0
7.4	02	A074021	2.5	18.0	2	A180201	4.0	39.0	5	A390501	8.0	60.0	6	A600601	10.0
7.5	02	A075021	2.5	18.0	3	A180301	5.0	40.0	5	A400501	8.0	61.0	6	A610601	10.0
8.0	02	A080021	2.5	18.5	3	A185301	5.0	41.0	5	A410501	8.0	62.0	6	A620601	10.0
8.3	02	A083021	2.5	19.0	2	A190201	4.0	42.0	5	A420501	8.0	63.0	6	A630601	10.0
8.4	02	A084021	2.5	19.0	3	A190301	5.0	43.0	5	A430501	8.0	64.0	6	A640601	10.0
8.5	02	A085021	2.5	20.0	2	A200201	4.0	44.0	5	A440501	8.0	65.0	6	A650601	10.0
9.0	1	A090101	3.0	20.0	3	A200301	5.0	45.0	5	A450501	8.0	66.0	6	A660601	10.0
9.4	1	A094101	3.0	20.5	3	A205301	5.0	46.0	5.5	A460551	9.0	67.0	6	A670601	10.0
9.5	1	A095101	3.0	21.0	3	A210301	5.0	47.0	5.5	A470551	9.0				
10.0	1	A100101	3.0	22.0	2	A220201	4.0								
10.4	1	A104101	3.0	22.0	3	A220301	5.0								
10.5	1	A105101	3.0	22.5	3	A225301	5.0								
11.0	1	A110101	3.0	23.0	3	A230301	5.0								
11.5	1	A115101	3.0	23.0	4	A230401	6.0								
12.0	1	A120101	3.0	24.0	3	A240301	5.0								
12.5	1	A125101	3.0	24.0	4	A240401	6.0								
13.0	1	A130101	3.0	25.0	3	A250301	5.0								
13.0	2	A130201	4.0	25.0	4	A250401	6.0								
13.5	1	A135101	3.0	26.0	3	A260301	5.0								
13.5	2	A135201	4.0	26.0	4	A260401	6.0								
14.0	1	A140101	3.0	27.0	4	A270401	6.0								
14.0	2	A140201	4.0	28.0	3	A280301	5.0								

A-HSS: Dimensions			
Size	E	NL	Rake Angle
00/01/02	23	8	25°
1	25	12	30°
2	30	14	
3	34	16	
4	38	18	
5	39	20	
5.5	40	24	25°
6	39	24	

Other dimensions, sizes and edge radii available upon request.

Cutting Data Recommendations:

HSS	Speed (SFM)	Steel	Stainless Steel	Cast Iron	Nonferrous Metal
		65-88	26-39	Not Recommended	55-88
∅4.5-8.5	Feed Rate (IPR)	.002-.003	.002-.003	Not Recommended	.004-.008
∅9.0-12.5		.004-.008	.004-.008		.008-.012
∅13.0-22.5		.006-.016	.006-.012		.010-.016
∅23.0-45.0		.010-.020	.008-.016		.012-.020
∅46.0-67.0		.016-.028	.012-.024		.016-.028

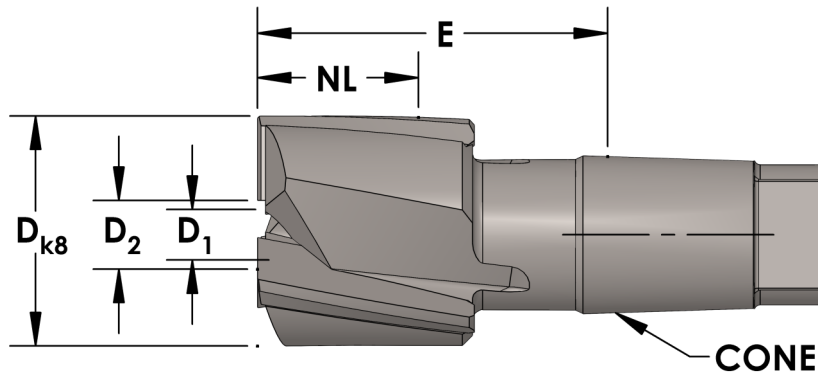

Counterbore A-HM (Carbide Tipped)

A-HM															
D	Cone Size	Order Number	D ₁	D	Cone Size	Order Number	D ₁	D	Cone Size	Order Number	D ₁	D	Cone Size	Order Number	D ₁
5.9	01	A059015	2.4	16.5	2	A165205	5.5	36.0	5	A360505	10.6	52.0	5.5	A520555	12.7
6.0	01	A060015	2.4	17.0	2	A170205	5.5	37.0	5	A370505	10.6	53.0	5.5	A530555	12.7
6.3	01	A063015	2.4	17.5	2	A175205	5.5	38.0	5	A380505	10.6	54.0	5.5	A540555	12.7
6.4	01	A064015	2.4	18.0	2	A180205	5.8	39.0	5	A390505	10.6	55.0	5.5	A550555	12.7
6.5	01	A065015	2.4	18.0	3	A180305	6.6	40.0	5	A400501	10.6	56.0	5.5	A560555	12.7
6.8	01	A068015	2.4	18.5	3	A185305	6.6	41.0	5	A410505	10.6	57.0	5.5	A570555	12.7
7.0	02	A070025	3.0	19.0	2	A190205	5.8	42.0	5	A420505	10.6	58.0	6	A580605	13.8
7.4	02	A074025	3.0	19.0	3	A190305	6.6	43.0	5	A430505	10.6	59.0	6	A590605	13.8
7.5	02	A075025	3.0	20.0	2	A200205	5.8	44.0	5	A440505	10.6	60.0	6	A600605	13.8
8.0	02	A080025	3.0	20.0	3	A200305	6.6	45.0	5	A450505	10.6	61.0	6	A610605	13.8
8.4	02	A084025	3.0	20.5	3	A205305	6.6	46.0	5.5	A460555	12.7	62.0	6	A620605	13.8
8.5	02	A085025	3.0	21.0	3	A210305	6.6	47.0	5.5	A470555	12.7	63.0	6	A630605	13.8
9.0	1	A090105	4.0	22.0	2	A220205	5.8	48.0	5.5	A480555	12.7	64.0	6	A640605	13.8
9.4	1	A094105	4.0	22.0	3	A220305	6.6	49.0	5.5	A490555	12.7	65.0	6	A650605	13.8
10.0	1	A100105	4.0	22.5	3	A225305	6.6	50.0	5.5	A500555	12.7	66.0	6	A660605	13.8
10.4	1	A104105	4.0	23.0	3	A230305	6.8	51.0	5.5	A510555	12.7	67.0	6	A670605	13.8
11.0	1	A110105	4.0	23.0	4	A230405	7.7								
11.5	1	A115105	4.0	24.0	3	A240305	6.8								
12.0	1	A120105	4.0	24.0	4	A240405	7.7								
12.5	1	A125105	4.0	25.0	3	A250305	6.8								
13.0	1	A130105	4.6	25.0	4	A250405	7.7								
13.0	2	A130205	5.5	26.0	3	A260305	6.8								
13.5	1	A135105	4.6	26.0	4	A260405	7.7								
13.5	2	A135205	5.5	27.0	4	A270405	7.7								
14.0	1	A140105	4.6	28.0	3	A280305	6.8								
14.0	2	A140205	5.5	28.0	4	A280405	7.7								
14.5	1	A145105	4.6	28.5	4	A285405	7.7								
14.5	2	A145205	5.5	29.0	4	A290405	7.7								
15.0	1	A150105	4.6	30.0	4	A300405	7.7								
15.0	2	A150205	5.5	31.0	4	A310405	7.7								
15.5	2	A155205	5.5	32.0	4	A320405	7.7								
16.0	1	A160105	4.6	33.0	4	A330405	7.7								
16.0	2	A160205	5.5	34.0	5	A340505	10.6								
16.5	2	A165105	4.6	35.0	5	A350505	10.6								

A-HM: Dimensions			
Size	E	NL	Rake Angle
01/02	23	8	8°
1	25	12	12°
2	30	14	
3	34	16	
4	38	18	
5	39	20	
5.5	40	24	
6	39	24	

Other dimensions, sizes and edge radii available upon request.

Cutting Data Recommendations:

HM	Speed (SFM)	Steel	Stainless Steel	Cast Iron	Nonferrous Metal
		131-295	65-164	131-328	196-492
∅5.0-8.5	Feed Rate (IPR)	Not Recommended	Not Recommended	.002-.004	.002-.004
∅9.0-12.0		Not Recommended	Not Recommended	.004-.008	.004-.008
∅13.0-22.5		.004-.010	.004-.010	.008-.012	.008-.012
∅23.0-45.0		.008-.020	.008-.020	.012-.020	.012-.020
∅46.0-67.0		.010-.020	.010-.020	.016-.024	.016-.028

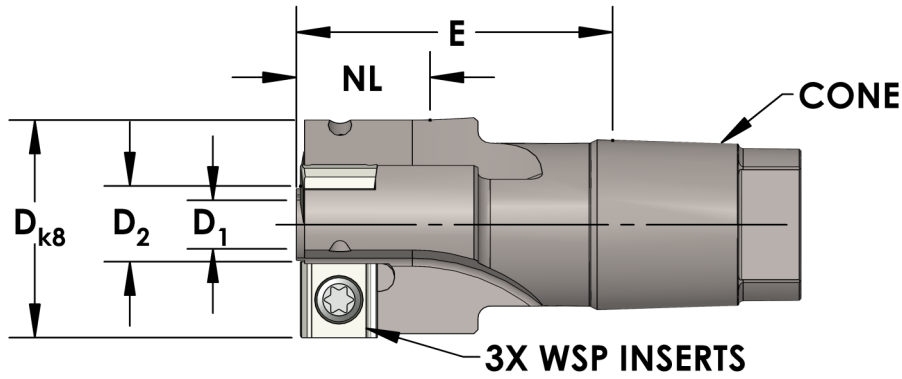

Counterbore AW (With Indexable Inserts)

AW										D	E	NL	Screw	Wrench		
D	Cone Size	Order Number	D ₁	WSP	D	Cone Size	Order Number	D ₁	WSP	20-27	28-33	34-39	40-45	46-49	50-57	58-67
20	3	AW20000	7.5	6	44	5	AW44000	20	12	TX25050	TX108-25					
21	3	AW21000	8.5	6	45	5	AW45000	21	12	TX35075	TX115-35					
22	3	AW22000	9.5	6	46	5.5	AW46000	22	12	TX35075	TX115-35					
23	4	AW23000	10.5	6	47	5.5	AW47000	23	12	TX45115	TX115-45					
24	4	AW24000	11.5	6	48	5.5	AW48000	24	12	TX45115	TX115-45					
25	4	AW25000	12.5	6	49	5.5	AW49000	25	12	TX45135	TX115-45					
26	4	AW26000	13.5	6	50	5.5	AW50000	21	15	TX45135	TX115-45					
27	4	AW27000	14.5	6	51	5.5	AW51000	22	15							
28	4	AW28000	9.2	9	52	5.5	AW52000	23	15							
29	4	AW29000	10.2	9	53	5.5	AW53000	24	15							
30	4	AW30000	11.2	9	54	5.5	AW54000	25	15							
31	4	AW31000	12.2	9	55	5.5	AW55000	26	15							
32	4	AW32000	13.2	9	56	5.5	AW56000	27	15							
33	4	AW33000	14.2	9	57	5.5	AW57000	28	15							
34	5	AW34000	15.2	9	58	6	AW58000	29	15							
35	5	AW35000	16.2	9	59	6	AW59000	30	15							
36	5	AW36000	17.2	9	60	6	AW60000	31	15							
37	5	AW37000	18.2	9	61	6	AW61000	32	15							
38	5	AW38000	19.2	9	62	6	AW62000	33	15							
39	5	AW39000	20.2	9	63	6	AW63000	34	15							
40	5	AW40000	16	12	64	6	AW64000	35	15							
41	5	AW41000	17	12	65	6	AW65000	36	15							
42	5	AW42000	18	12	66	6	AW66000	37	15							
43	5	AW43000	19	12	67	6	AW67000	38	15							

* Round ground guiding chamfers on the insert helps to prevent chattering and burnish the bore surface. Well suited for lean tools with 3 or more cutting edges.

** Low cutting and short chip breakers generate short chips already at low feed rates. Well suited for long chipping materials.

Other dimensions, sizes and edge radii available upon request.

AW Boring Inserts		Size	Order Number	Grade						
Ground Chip Breakers		06	SCHX060204 FRH...	AK1	K1	K9	P2	P5	P9	
		09	SCHX090304 FRH...	AK1	K1	K9	P2	P5	P9	S6
		12	SCHX120404 FRH...	AK1	K1	K9	P2	P5	P9	S6
		15	SCHX150604 FRH...	AK1		K9		P5	P9	S6
Guiding Chamfers* Ground Chip Breakers		06	SCHX060204 FRZ...	AK1	K1	K9	P2	P5	P9	S6
		09	SCHX090304 FRZ...	AK1	K1	K9	P2	P5	P9	S6
		12	SCHX 120404 FRZ...	AK1	K1	K9	P2	P5	P9	S6
		15	SCHX 150604 FRZ...	AK1	K1	K9	P2	P5	P9	S6
Guiding Chamfers* Chip Breakers** for short chip		06	SCHX060204 FRZ7...						P9	
		09	SCHX090304 FRZ7...						P9	
		12	SCHX120404 FRZ7...						P9	
AW Spotfacing Inserts		Size	Order Number	Grade						
Without Chip Breakers		06	SCHW060204 FN...		K1	K9				
		09	SCHW090304 FN...		K1	K9	P2			
4 Ground Chip Breakers		06	SCHX060202 FN1...		K1		P2	P5		
		09	SCHX090304 FN1...		K1		P2	P5		
4 Sintered Chip Breakers		06	SCMT060204 EN...		K1	K9	P2	P5		
		09	SCMT090304 EN...		K1	K9	P2	P5		
		12	SCMT120404 EN...		K1	K9		P5		
		15	SCMT150604 EN...		K1	K9		P5		

AW Inserts (...Continued)

AW Indexable Insert Grades								
Grade	DIN ISO 513	Cutting Material	Steel	Stainless Steel	Cast Iron	Nonferrous Metals	Nickel and Titanium Alloys	Hard Materials
AK1	HF-N20	HM/Carbide			o	+	o	
K1	HF-K20	HM/Carbide			+			
K9	HC-K10	HM/Carbide - TiAlN		o	+			o
P2	HF-P30	HM/Carbide	+					
P5	HC-K40/P40	HM/Carbide - TiN	+	+	o			
P9	HC-P10	HM/Carbide - TiAlN	+	+	o			o
S6	-	HSSE-TiN	+	+	o		+	

"+" = Main Application

"o" = Minor application

AW Cutting Data Recommendations:

		Steel	Stainless Steel	Cast Iron	Nonferrous Metal
HM/Carbide	Speed (SFM)	196-492	131-295	196-492	328-640
HSSE (S6)	Speed (SFM)	82-164	49-114	<i>Not Recommended</i>	<i>Not Recommended</i>
Ø20-30	Feed Rate (IPR)	.005-.012	.004-.008	.006-.012	.008-.014
Ø31-45		.008-.014	.006-.010	.010-.020	.010-.020
Ø46-67		.010-.016	.008-.012	.012-.024	.012-.024

Countersink E-HSS / B-HSS

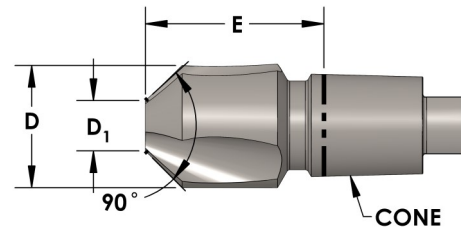
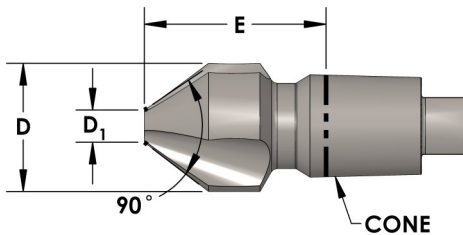

E-HSS 90°									
D	Cone Size	Order Number	D ₁	E	D	Cone Size	Order Number	D ₁	E
8	0	E080901	2	23	25	3	E250901	6	39
12	1	E120901	3	25	30	4	E300901	8	39
15	2	E150901	4	30	45	5	E450901	15	40
20	3	E200901	5	34	60	6	E600901	25	39

Rake Angle: 20°

B-HSS 90° With Pilots Used									
D	Cone Size	Order Number	D ₁	E	D	Cone Size	Order Number	D ₁	E
9.4	1	B09411	4.8	20	23	4	B23011	9.8	32
10.0	1	B10011	4.8	20	25	4	B25011	9.8	32
10.4	1	B10411	4.8	20	26	4	B26011	9.8	32
11.5	1	B11511	4.8	20	28	4	B28011	9.8	32
12.4	1	B12411	4.8	20	30	4	B30011	9.8	32
13.4	1	B13411	5.8	20	31	4	B31011	9.8	32
15.0	2	B15011	5.8	21	34	5	B34011	14.8	40
16.5	2	B16511	5.8	21	37	5	B37011	14.8	40
19.0	3	B19011	7.8	27	46	5	B46011	15	40
20.5	3	B20511	7.8	27					

Rake Angle: 20°

E-HSS / B-HSS Cutting Data Recommendations:

		Steel	Stainless Steel	Cast Iron	Nonferrous Metal
HSS	Speed (SFM)	65-88	26-39	<i>Not Recommended</i>	58-89
Ø8-12.5	Feed Rate (IPR)	.002-.004	.002-.004	<i>Not Recommended</i>	.002-.004
Ø13-22.5		.003-.006	.003-.006		.003-.006
Ø23-45		.004-.010	.004-.008		.005-.012
Ø46-60		.008-.012	.006-.012		.006-.014

Holder H

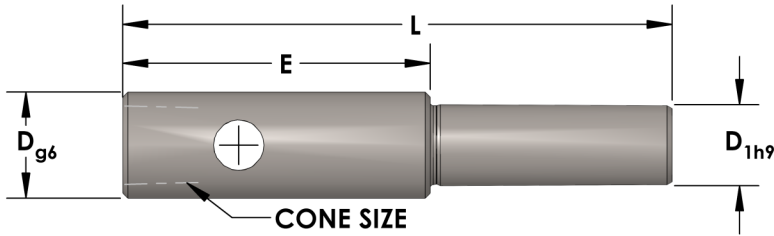

H (Cylindrical Shank)							
Cone Size	D	D ₁	E	L	Order Number	Ejector H	Ejector HB
0	9.0	6	24	59	H1000		HB900
			50	85	H2000*		
1	12.5	8	25	76	H1100	HB10	HB910
				114	H2100*		
2	17.0	10	30	91	H1200	HB20	HB920
3	21.0	12	34	109	H1300	HB30	HB930
4	28.0	14	30	112	H1400	HB40	HB940
5	32.0	16	34	125	H1500	HB50	HB950

* Long version

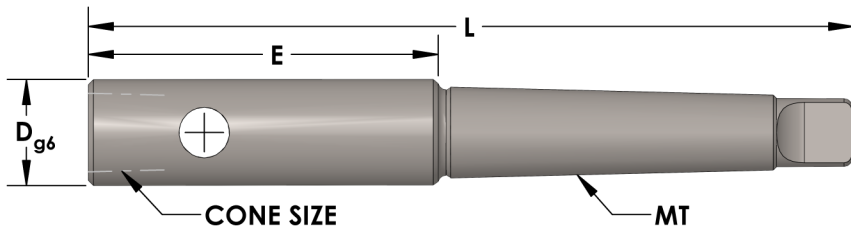

H (Morse Taper Shank)							
Cone Size	D	MT	E	L	Order Number	Ejector H	Ejector HB
1	12.5	1	42	104	H1101	H810	HB910
			80	142	H2101*		
2	17.0	1	47	109	H1201	H820	HB920
			90	152	H2201*		
		2	49	124	H1202		
			92	167	H2202*		
3	21.0	1	55	117	H1301	H830	HB930
			108	170	H2301*		
		2	57	132	H1302		
			110	185	H2302*		
			58	152	H1303		
4	28.0	2	60	135	H1402	H840	HB940
			115	190	H2402*		
		3	61	115	H1403		
			116	210	H2403*		
5	32.0	2	73	148	H1502	H850	HB950
			3	74	168		
		141		235	H2503*		
5.5	37.0	3	84	178	H1553	H855	HB955
			161	255	H2553*		
		4	85	203	H1554		
6	42.0	3	86	180	H1603	H860	HB960
			4	87	205		

* Long version

EJECTOR H FOR COUNTERBORE WITH PILOT

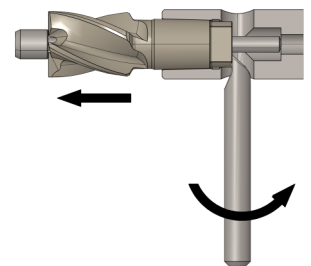

EJECTOR HB FOR COUNTERBORE WITHOUT PILOT

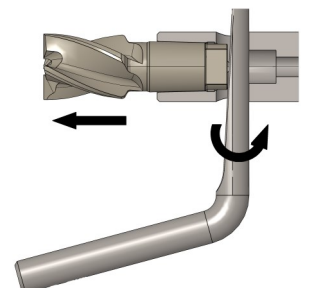



GZ (Pilots, cone size 01-02)			
Cone Size	D	L ₁	Order Number
01	4.0	5.5	GZ3010400
02	3.0		GZ3020300
	4.0		GZ3020400
	4.5		GZ3020450
	5.0		GZ3020500

Other diameters upon request

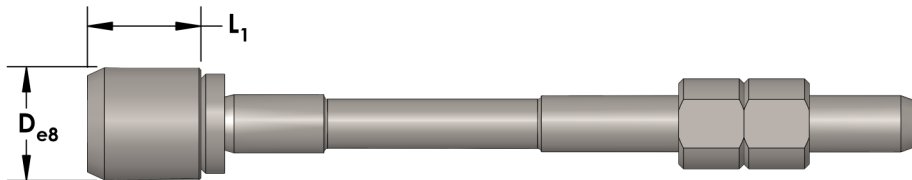

GZ (Pilots, cone size 1-5) Consisting of pilot, washer and 2 screws nuts GZ															
Cone Size	D	L ₁	Order Number	Cone Size	D	L ₁	Order Number	Cone Size	D	L ₁	Order Number	Cone Size	D	L ₁	Order Number
1	4.5	7	GZ1100450	1	9.0	7	GZ1100900	3	6.0	10	GZ1300600	4	9.0	12	GZ1400900
	4.8		GZ1100480		4.0		GZ1200400		6.5		GZ1300650		10.0		GZ1401000
	5.0		GZ1100500		5.0		GZ1200500		7.0		GZ1300700		10.5		GZ1401050
	5.5		GZ1100550		6.0		GZ1200600		8.0		GZ1300800		11.0		GZ1401100
	5.7		GZ1100570		6.3		GZ1200630		8.5		GZ1300850		11.5		GZ1401150
	5.8		GZ1100580		6.5		GZ1200650		9.0		GZ1300900		12.0		GZ1401200
	5.9		GZ1100590		7.5		GZ1200750		9.5		GZ1300950		13.0		GZ1401300
	6.0		GZ1100600		8.0		GZ1200800		10.0		GZ1301000		15.0*		GZ2401500
	6.4		GZ1100640	2	8.3	10	GZ1200830		10.5		GZ1301050	16.0*	GZ2401600		
	6.5		GZ1100650		8.4		GZ1200840		11.0*		GZ2301100	17.0*	GZ2401700		
	6.6		GZ1100660		8.5		GZ1200850		11.5*		GZ2301150	18.0*	GZ2401800		
	6.8		GZ1100680		9.0		GZ1200900		12.0*		GZ2301200	20.0*	GZ2402000		
	7.0		GZ1100700	10.0	GZ1201000	13.0*	GZ2301300		22.0*		GZ2402200				
	7.5		GZ1100750	10.7*	GZ2201070	13.5*	GZ2301350		5		8.5	18	GZ1500850		
	7.8		GZ1100780	11.0*	GZ2201100	14.0*	GZ2301400				10.2		GZ1501020		
	8.0		GZ1100800	11.6*	GZ2201160	4	8.0				GZ1400800		15.0	GZ1501500	
8.5	GZ1100850	3	5.0	10	GZ1300500		8.5	12		GZ1400850	17.0		GZ1501700		

* Two parts

Installation Information

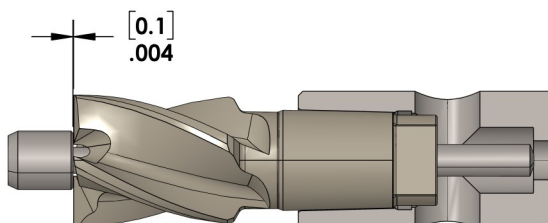

Disc should be assembled with 0.1mm space between pilot and counterbore to protect carbide

Holder HBS/HB

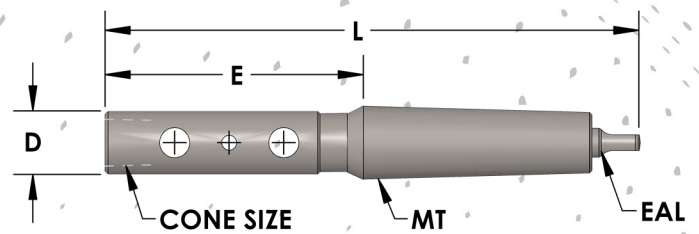
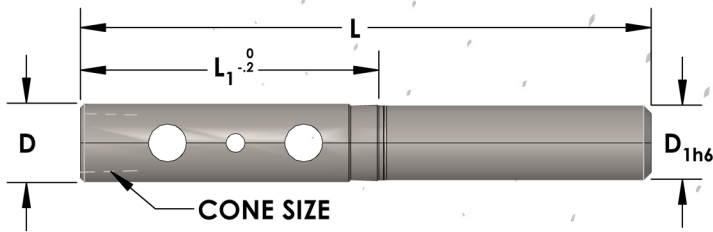

HBS (Cylindrical Shank)						
Cone Size	D	D ₁	L ₁	L	Order Number	Ejector HB
1	12	8	59	95	HBS1008	HB910
2	18	10	69	109	HBS2010	HB920
3	21	12	81	126	HBS3012	HB930
4	28	14	93	138	HBS4014	HB940
5	32	16	107	155	HBS5016	HB950
5.5	37	20	112	162	HBS5520*	HB955

HBS (Morse Taper Shank)							
Cone Size	D	MK	E	L	Order Number	EAL**	Ejector HB
1	12.5	1	65	127	HB1101		HB910
2	18.0	1	75	137	HB1201		HB920
		2	77	152	HB1202	EAL012	
3	21.0	1	87	149	HB1301		HB930
		2	89	164	HB1302	EAL012	
		3	90	184	HB1303	EAL013	
4	28.0	2	101	176	HB1402	EAL012	HB940
		3	102	196	HB1403	EAL013	
5	32.0	2	115	190	HB1502	EAL012	HB950
		3	116	210	HB1503	EAL013	
5.5	37.0	4	117	235	HB1504	EAL014	HB955
		3	121	215	HB1553	EAL013	
6	42.0	4	122	240	HB1554	EAL014	HB955
		3	133	227	HB1603	EAL013	
		4	134	252	HB1604	EAL014	HB960

* Weldon Shank DIN 1835-B20

** After removing EAL, Morsetaper can be secured by thread.

Delivery includes extractor pin HB for tool securing.

Securing Tool with pilot HB

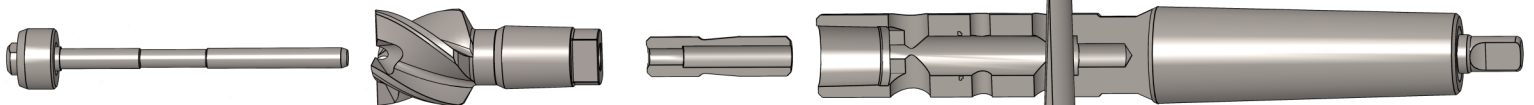

Remove parts from holder-bore. Screw extractor closer HB on the pilot HB installed in the tool and lock it in the holder HB resp. HBS with 2 set screws.

Securing Tool without pilot HB

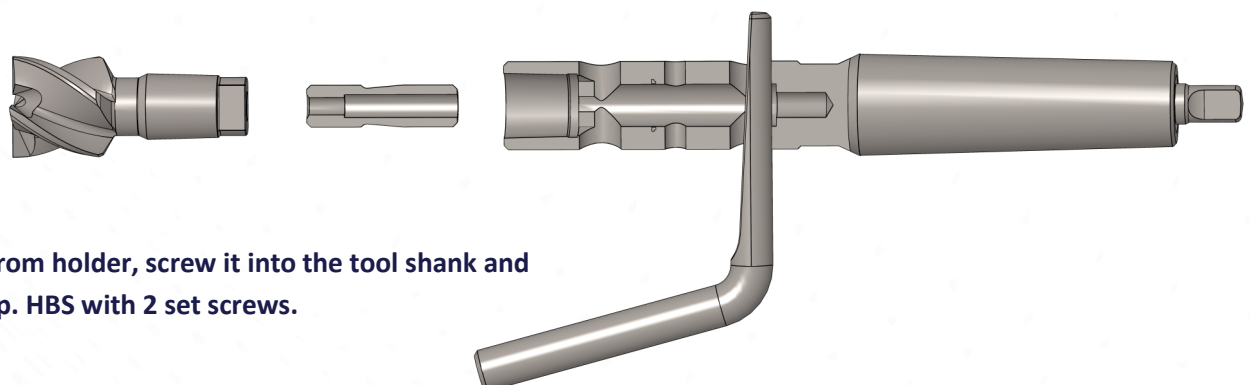

Remove extractor pin HB from holder, screw it into the tool shank and lock it in the holder HB resp. HBS with 2 set screws.

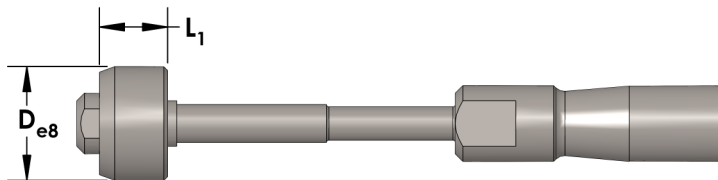

Pilots Set HB															
Consisting of pilot HB and extractor closer HB															
Cone Size	D	L ₁	Order Number	Cone Size	D	L ₁	Order Number	Cone Size	D	L ₁	Order Number	Cone Size	D	L ₁	Order Number
1	8.0	11	HB100800	2	11.6	14	HB201160	3	13.5	14	HB301350	4	18.0	17	HB401800
	8.5		HB100850		10.0		HB301000		14.0		HB301400		20.0		HB402000
	9.0		HB100900		10.5		HB301050		12.0		HB401200		22.0		HB402200
2	9.0	14	HB200900	3	11.0	14	HB301110	4	13.0	17	HB401300	5	15.0	23	HB501500
	10.0		HB201000		11.5		HB301150		15.0		HB401500		17.0		HB501700
	10.7		HB201070		12.0		HB301200		16.0		HB401600				
	11.0		HB201100		13.0		HB301300		17.0		HB401700				

* Additional cone sizes and diameters available upon request

Countersink EW with changeable inserts 90°

- Universally usable for soft and hard materials.
- Relieved ground inserts for chatter free countersinking and deburring.
- Three changeable inserts are fixed by a central screw.

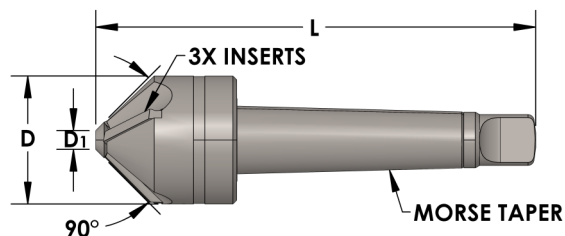
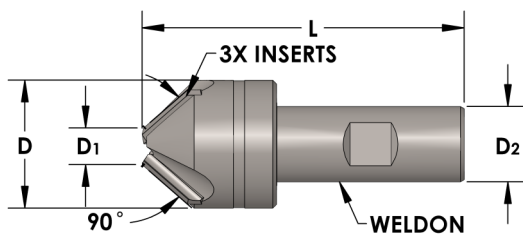

EWZ (Cylindrical Shank)					
D	D ₁	D ₂	L	Order Number	Inserts
35	12	20	88	EWZ3590	EW4...
50	18	25	102	EWZ5090	EW5...
80	25	32	120	EWZ8090	EW6...

EWM (Morse Taper Shank)					
D	D ₁	MK	L	Order Number	Inserts
35	12	2	125	EWM3590	EW4...
50	18	3	151	EWM5090	EW5...
80	25	4	188	EWM8090	EW6...

Changeable Inserts for EWZ and EWM				
Cutting Material				
Inserts	HF-K20	HC-P30-TiN	HSSE-TiN	for Hardox
EW4...	EW4K1	EW4P5	EW456	EW4WP9
EW5...	EW5K1	EW5P5	EW556	EW5WP9
EW6...	EW6K1	EW6P5	EW656	EW6WP9
	KN	PM	PM	H